



# HOLTEK Battery Charger Solutions



# Introduction

With the technical maturity of the rechargeable lead acid battery and lithium battery, their output power has gradually improved, they have been widely used in various power products, such as electric vehicles, gardening tools, electric tools, etc.

The lead acid battery has the characteristics of low price, high stability and low accident rate, which is widely used in low-end markets, such as two-wheel and three-wheel electric vehicles. However, the lead acid battery has the disadvantage of heavy weight, makes it not suitable for lightweight products. Products with weight requirements, such as hand-held tools and vacuum cleaners will select lithium batteries with higher prices because of their irreplaceable advantages, such as high energy density and light weight.

No matter which kind of rechargeable battery products mentioned above, it needs to be used together with the charger to achieve the charging purposes.

## I Charger Operating Principle

As shown in Figure 1, chargers generally use AD/DC converters with power below 150W. To ensure the power safety and the charge management feedback output control, the isolated flyback secondary side feedback regulation (SSR) conversion architecture will be used. The PWM IC will be used together to achieve the Switch Mode Power Supply (SMPS) control. The left side of the transformer is the primary side and the right side of the transformer is the secondary side. The charger output voltage and current are controlled by the PWM IC output duty cycle on the primary side. The charger must adjust the charger output voltage and current according to the battery charging state. Therefore, it is necessary to judge the battery status through the charge management feedback control circuit on the secondary side. The control signal will be fed back to the primary side PWM IC to control the PWM duty cycle, and then through the optical coupling IC to achieve the battery charge management feedback control.

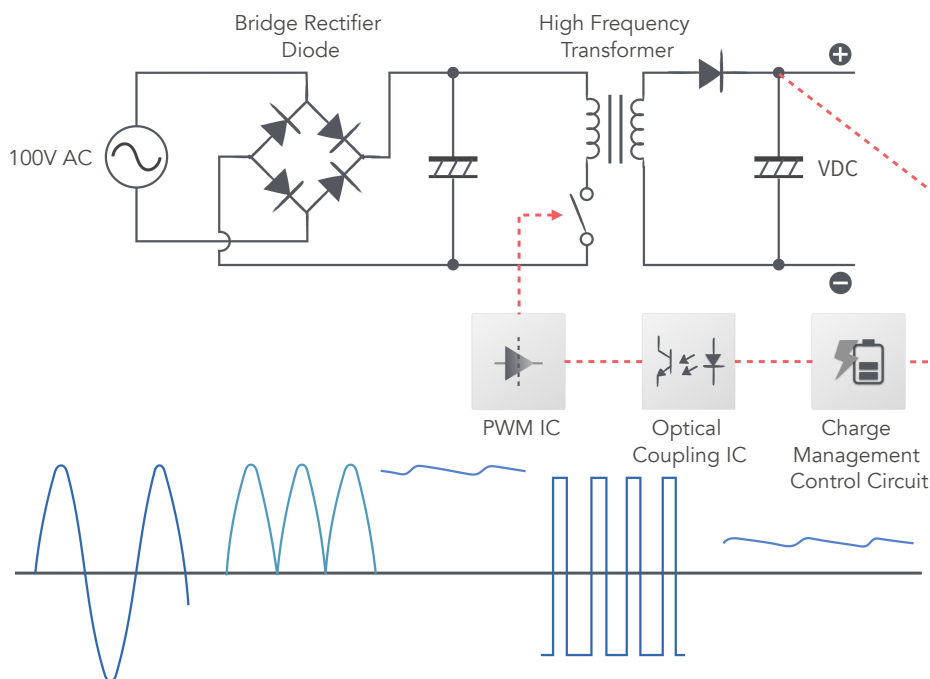

Figure 1. Charger Operating Principle

# I Charger Marked Specifications and Batteries Relationship

No matter lead acid battery or lithium battery, the number of batteries used in series and in parallel will vary according to the terminal product type and the required battery specifications. Therefore, the rechargeable battery must be charged with a dedicated charger.

For example:

- There are four common lead acid battery charger specifications for 2-wheel and 3-wheel electric vehicles. Each specification and the number of lead acid batteries in series are listed in the following table.

Number of Lead Acid Batteries in Series	Charger Marked Voltage	Charger Marked Current
4S	48V	2A~3A
5S	60V	
6S	72V	1.5A~2A
8S	96V	

Table 1. 2-wheel and 3-wheel Electric Vehicles Lead Acid Battery Charger

- There are three lithium battery charger specifications for electric tools. Each specification and the number of batteries in series are listed in the following table.

Number of Lithium Batteries in Series	Charger Marked Voltage	Charger Marked Current
3S	10.8V	2A
4S	14.4V	
5S	18V	

Table 2. Electric Tool Lithium Battery Charger

It can be seen from the above that the charger output voltage and current are different in different application products.

*For the charger application, Holtek has specially developed a series of dedicated MCUs, which have the main characteristics of integrating a special control circuit, including two D/A converters and two OPAs.*

The charger product developed by these dedicated MCUs can accurately control the output voltage and current at the same time. The charger output voltage and current will be changed according to the current battery charging state. As shown in the figure below, the complete charging process management will be implemented, which is divided into four stages, namely trickle current mode (TC mode), constant current mode (CC mode), constant voltage mode (CV mode) and float voltage mode (FV mode). It not only improves the battery service life, but also provides multiple protection functions, such as overcharge voltage, overcharge current, temperature monitoring and charging time, which greatly reduce the probability of battery explosion and other abnormalities during charging.

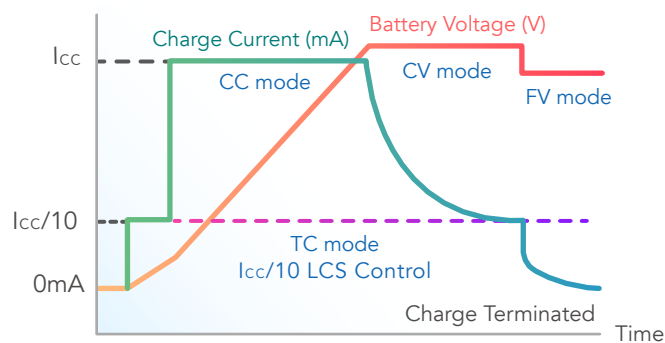

Figure 2. Charging Process

# Holtek Charger Solutions

The HT45R/F5Q and the HT45R6Q series devices are Holtek charger dedicated MCUs, which have 10 products and 6 packages and 2KW, 4KW, 8KW, 16KW program space in total.

The target product requirements, rechargeable battery types and battery numbers of the HT45R/F5Q and the HT45R6Q series of MCUs are summarized as follows:

HT45F5Q-2A / HT45R5Q-2	Standard chargers, multiple voltages, current control and controlled accurately.
HT45F5Q-3 / HT45R5Q-3	The charger can be designed according to the platform, with more program space. A group of programs can be used for different products, which may have different battery types and serial numbers.
HT45R6Q-2 / HT45R6Q-3	Integrated peripherals such as a 5V LDO and fan driver.
HT45F5Q-5 / HT45F5QC-5 HT45F5Q-6 / HT45F5QC-6	It has rich resources and communication interfaces, such as the Can Bus can communicate with BMS and identify battery characteristics.

## I Application Block Diagram

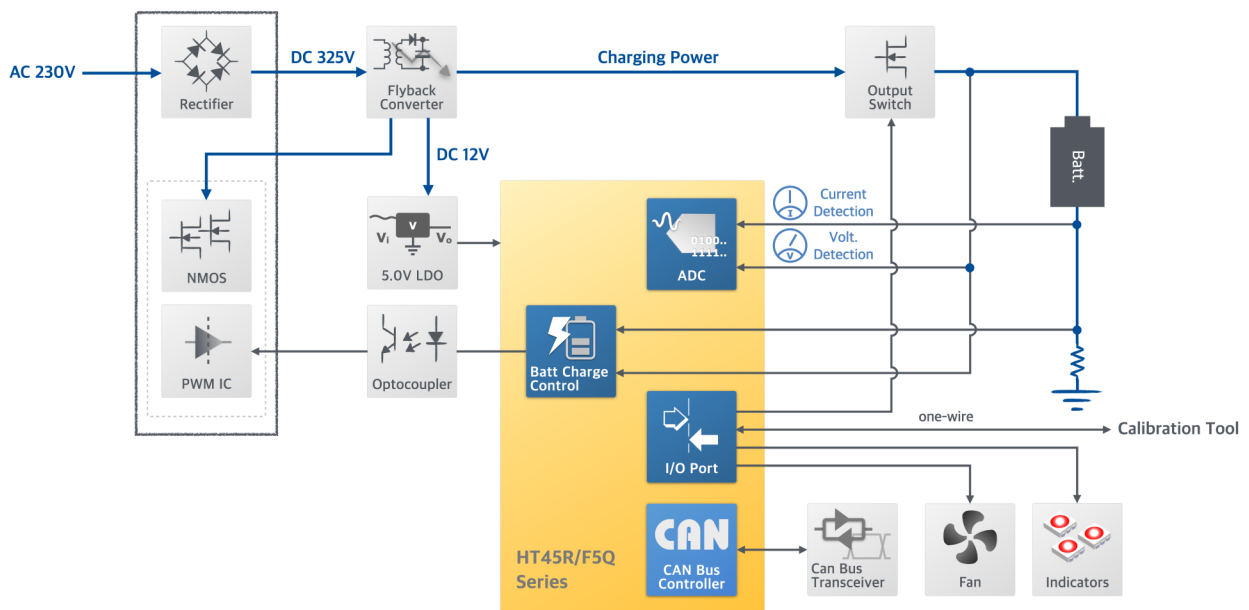

Figure 3-1. HT45R/F5Q Series Charger Application Block Diagram

# I Application Block Diagram

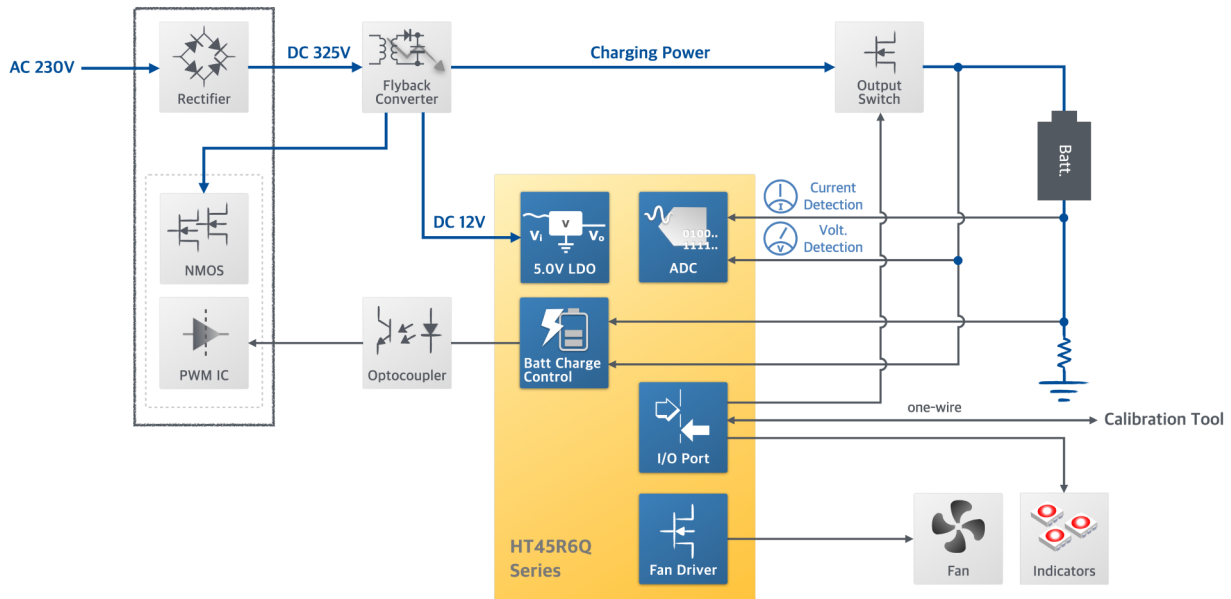

Figure 3-2. HT45R6Q Series Charger Application Block Diagram

## I Feature Description

- The HT45R/F5Q and the HT45R6Q series devices are charger dedicated MCUs, each device in this series has a dedicated control circuit, including two D/A converters and two OPAs for constant voltage and constant current control. The D/A converters resolution can be 12-bit or 14-bit. These circuits are used to control the charger voltage and current at different stages according to the battery status.
- The traditional circuit architecture adjusts the constant voltage and constant current by adjusting the resistance value of fixed resistor. It is easily limited by the resistance accuracy and error, may not output suitable voltage and current. However, Holtek's solution is controlled by the D/A converter, which not only has high resolution, but also calibrates the whole machine through production fixtures during mass production to improve the production efficiency.
- An additional OPA is provided to amplify the current signal. Together with the MCU internal A/D converter, the battery charge current can be accurately read. It can realize small current judgment when the battery is fully charged and overcurrent judgment for overcurrent protection. At the same time, the heat can be reduced to improve the conversion efficiency by reducing the current detection resistance value.

# Charger Development Workshop

The traditional charger manufacturers have the ability to design the AC/DC circuit, but the F/W development ability is relatively insufficient. Therefore, Holtek has developed the "Charger Development Platform" to help users quickly develop charger applications through graphical interface operations without program programming.

## I Charger Development Platform Main Features

- *This development platform provides a graphical interface, which can support the full series charger dedicated MCUs, the HT45R/F5Q and the HT45R6Q.* It is useful for users to select the required battery type and serial number through simple settings. The platform not only provides general voltage and current parameters, but also can modify the voltage and current parameters according to requirements. In addition to the basic charging operations, the platform also can provide over temperature protection, fan control, LED lamp control and other common charger functions, which will short the charger development cycle.
- *This development platform can generate an MCU programming file after setting, which has the basic charge voltage and current control modes.* The code can be programmed into the MCUs only by using Holtek's programmer, the e-WriterPro and the programming software, the HOPE3000. Then the charger hardware test can be implemented. Therefore, in the early stage of charger development, the hardware engineer can repeatedly adjust the optocoupler related RC response circuit to verify the output voltage and current stabilities. It can also be used for long-term programming to test hardware stability.
- *When developing on this platform, the corresponding software engineering files can be produced at the same time, which are provided for software engineers to implement a secondary development and customization according to product requirements.* For example, it is used to develop human machine interface functions such as charging lamp flashing type. The HT-IDE3000 project file is a software project generated by the development platform and needs to be programmed on the PC through the HT-IDE3000 software.

## I Charger Development Platform Link

[https://www.holtek.com/page/tool-detail/dev\\_plat/power/Charger\\_Development\\_Workshop](https://www.holtek.com/page/tool-detail/dev_plat/power/Charger_Development_Workshop)

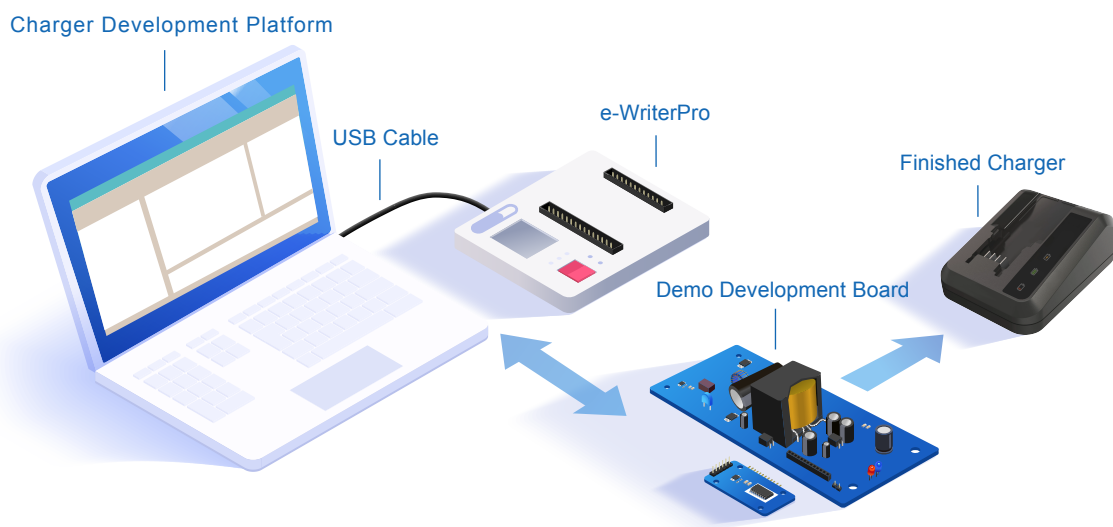

Figure 4. Holtek Charger Development Platform Development Process

# Charger Volume Production Fixture Platform

Manufacturers had to make the entire PCBA calibration before leaving the factory to ensure that the charger output voltage and current values meet the product specifications. The traditional calibration method to obtain the required resistance is to parallel the resistor or rotate the variable resistor. In these methods, the resistance may not match the required output voltage and current or the resistance value may change due to the wrong touch when setting the variable resistance and sealing the sealant. In addition, at least two workers need to be arranged for the production line. To solve the above problems, the Holtek charger volume production fixture is provided. It can not only improve the production speed of the production line, but also effectively reduce the labor cost.

## I Charger Volume Production Fixture Platform Main Features

- The fixture platform includes software and hardware, the development process is shown in the figure below.
  - **Platform software:** The charger volume production fixture platform is a graphical interface software on the PC.
  - **Matching hardware:** Charger Volume Production Fixture.
- Support the charger developed by the HT45R/F5Q and the HT45R6Q series.
- With multi-section output voltage and current, including trickle current, constant current, constant voltage and floating voltage, which are accurately and quickly calibrated and stored in the EEPROM integrated with MCU.
- The efficiency of mass production can be improved, optimize the resistance value from manual adjustment to digital communication calibration, it will greatly reduce the time cost and error probability.
- Only one production line worker needs to be arranged to save labor costs.
- PC software – The volume production fixture platform can adjust the calibration parameters at any time during the production process, it can store up to 10 groups of parameters. The production calibration parameters can be transferred to the volume production fixture via a USB cable. Therefore, when the voltage and current specifications of the chargers produced by the same production line are different, the fixture parameters can be quickly modified.

## I Charger Volume Production Fixture Platform Link

[https://www.holtek.com/page/tool-detail/dev\\_plat/power/Charger\\_Volume\\_Production\\_Fixture](https://www.holtek.com/page/tool-detail/dev_plat/power/Charger_Volume_Production_Fixture)

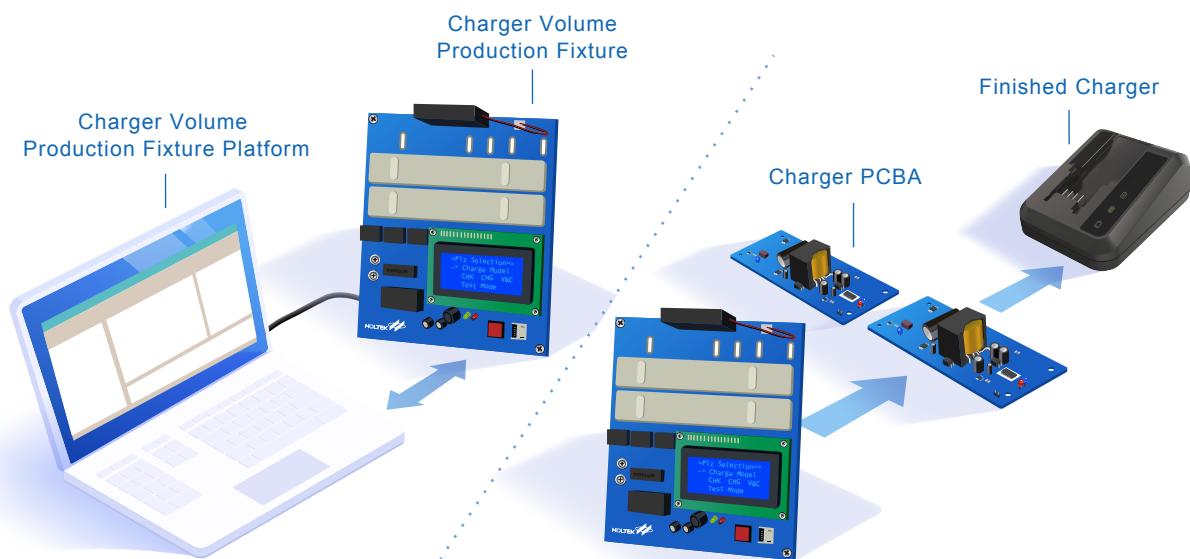

Figure 5. Holtek Charger Volume Production Fixture Platform Development Process

# Electric Bicycle Charger Application Solution

The charger circuit includes a bridge rectifier, an isolation transformer, a PWM IC, a secondary side control circuit, an MCU and other related circuits. Holtek provides an electric bicycle charger application solution on the official website, which includes the operating principle description, the PCB file and the circuit file. If the Holtek Charger dedicated control circuit is used, it automatically controls constant voltage or constant current charging according to the current battery status, greatly reducing the software burden and simplifying the peripheral circuitry. At the same time, it can together with the charger development platform to produce program code for development verification.

## Electric Bicycle Charger Application Solution Link

<https://www.holtek.com/page/applications/detail/WAS-1772>



# Holtek Charger MCU Selection Guide

Please refer to the official website for the latest selection information.

AC Charger Flash MCU															
Part No.	Max. Freq.	VDD	Program Memory	Data Memory	Data EEPROM	IAP	ADC	Timer	OPA	DAC	CAN	Interface	I/O	Package	
HT45F5Q-2A	8MHz	2.2V~5.5V	2K×15	128×8	32×15	—	12-bit ×7	10-bit CTM×1	3	12-bit×1 14-bit×1	—	UART×1	15	16NSOP 20NSOP	
HT45F5Q-3	8MHz	2.2V~5.5V	4K×15	256×8	32×15	—	12-bit ×11	10-bit CTM×1, 10-bit STM×1	3	12-bit×1 14-bit×1	—	UART×1 SPI/I <sup>2</sup> C×1	23	24SSOP 28SSOP	
HT45F5Q-5	8MHz	2.2V~5.5V	8K×16	512×8	512×8	√	12-bit ×12	10-bit CTM×1 10-bit STM×1, 16-bit STM×1	3	14-bit×2	—	UART×1 SPI/I <sup>2</sup> C×1	27	24/28SSOP 32QFN	
HT45F5Q-6	20MHz	2.7V~5.5V	16K×16	1024×8	1024×8	√	12-bit ×12	10-bit PTM×2, 10-bit CTM×1 10-bit STM×1, 16-bit STM×1	3	14-bit×2	—	UART×1 SPI/I <sup>2</sup> C×1	27	24/28SSOP 32QFN	
HT45F5QC-5	8MHz	2.2V~5.5V	8K×16	512×8	512×8	√	12-bit ×9	10-bit CTM×1, 10-bit STM×1 16-bit STM×1	3	14-bit×2	√	—	16	28SSOP 32QFN	
HT45F5QC-6	20MHz	2.7V~5.5V	16K×16	1024×8	1024×8	√	12-bit ×9	10-bit PTM×2, 10-bit CTM×1 10-bit STM×1, 16-bit STM×1	3	14-bit×2	√	UART×1	16	28SSOP 32QFN	

AC Charger OTP MCU															
Part No.	Max. Freq.	VDD	Program Memory	Data Memory	ORPP	ADC	Timer	OPA	DAC	HVO	LDO	Interface	I/O	Package	
HT45R5Q-2	8MHz	2.2V~5.5V	2K×16	128×8	√	12-bit ×5	8-bit×1	3	12-bit ×2	—	—	—	11	16NSOP 16QFN	
HT45R5Q-3	8MHz	2.2V~5.5V	4K×16	256×8	√	12-bit ×10	10-bit CTM×1 10-bit STM×1	3	14-bit ×2	—	—	UART×1 SPI/I <sup>2</sup> C×1	23	24SSOP 28SSOP	
HT45R6Q-2	8MHz	2.2V~5.5V	2K×16	128×8	√	12-bit ×4	8-bit×1	3	12-bit ×2	1xLS 30V	5V/30mA	—	10	16NSOP 20NSOP	
HT45R6Q-3	8MHz	2.2V~5.5V	4K×16	256×8	√	12-bit ×7	10-bit CTM×1 10-bit STM×1	3	14-bit ×2	1xLS 30V	5V/30mA	UART×1 SPI/I <sup>2</sup> C×1	15	24SSOP	

# Development Tools

The e-Link is an online debug adaptor for Holtek's new generation of OCDS architecture Flash MCUs. Together with the HT-IDE3000 software it allows users to program and debug programs on their target boards.

## I Online Debug Adapter

- Hardware: [e-Link](#)
- Software: [HT-IDE3000](#)
- Functions:
  - ✓ Supports online debug for EV devices that have an OCDS interface.
  - ✓ e-Link can perform debug operations such as single step, full speed, stop, breakpoints during the debug process.



Support 8-bit MCUs



Together with the HT-IDE3000 software



[Best Modules Online Shop](#)

## I Programmer

- Hardware: [e-WriterPro](#)
- Software: [HOPE3000](#)
- Functions:
  - ✓ The e-WriterPro is a programmer designed for programming of the Holtek MCUs.
  - ✓ This programmer supports an Online Programming Mode that needs to connect with a PC and an Offline Programming Mode that does not require a PC connection.



Support 8-bit MCUs



Together with the HOPE3000 software



[Best Modules Online Shop](#)



Holtek Semiconductor Inc.

**Holtek Semiconductor Inc. (Headquarters)**

No.3, Creation Rd. II, Science park, Hsinchu 300, Taiwan  
Email: sales@holtek.com

**Holtek Semiconductor Inc. (Taipei Sales Office)**

4F-2, No. 3-2, YuanQu St., Nankang Software Park,  
Taipei 115, Taiwan  
Email: sales@holtek.com.tw

**Holtek Semiconductor (India) Pvt.Ltd.**

The Oriental Towers No. 461, 2nd Floor, 4th Sector,  
17th Cross Rd, HSR Layout, Bengaluru, Karnataka 560102  
Email: Indiasales@holtek.com.tw

*Sharing Success Through Excellence*

**Holtek Semiconductor (China) Inc.**

Room 101, Office Building 10, Xinzhu Yuan, No. 4 Xinzhu Road,  
Songshan Lake, Dongguan, China  
Email: sales@holtek.com.cn

**Holtek Semiconductor (India) Pvt.Ltd. (Delhi Branch)**

Premises No. JA0608, 6th Floor, DLF Tower A, Jasola,  
New Delhi-110025  
Email: bharath@holtek.com.tw



Holtek  
Official Website



Best Modules  
Online Shop

Dec. 2025\_V004