



---

# HOPE5000 User Guide

Revision: V1.00 Date: May 09, 2024

[www.holtek.com](http://www.holtek.com)

## Table of Contents

<b>Chapter 1 Software Introduction .....</b>	<b>4</b>
General Description .....	4
Software Download .....	4
Software Installation .....	4
System Requirement .....	5
<b>Chapter 2 Function Introduction .....</b>	<b>6</b>
File .....	6
Programming .....	7
Smart Programming .....	8
Setting .....	9
Help .....	10
Advanced Function .....	11
<b>Chapter 3 Programming MCU .....</b>	<b>12</b>
Load Programming File .....	12
Programming Settings .....	13
Executing the Programming Operation .....	15
<b>Chapter 4 Offline Programming Function .....</b>	<b>19</b>
Smart Programming Function Configuration .....	19
Offline Programming Usage .....	21
Advanced Function .....	21
<b>Chapter 5 HOPE5000 Supported Writer .....</b>	<b>27</b>
<b>Chapter 6 e-WriterPro Introduction .....</b>	<b>28</b>
Introduction .....	28
Installation .....	28
Hardware Configuration .....	29
<b>Chapter 7 e-WriterPro2 Introduction .....</b>	<b>31</b>
Introduction .....	31
Installation .....	31
Hardware Configuration .....	32
<b>Chapter 8 Gang-Writer00-8 Introduce .....</b>	<b>37</b>
Main Features .....	37
Hardware Introduction .....	37
Programming Module Independent Operation .....	38
Using the Programming Module together with the Base Board .....	40
Programming Mode Selection .....	42
Base Board LCM Display Introduction .....	43
Considerations .....	44
<b>Chapter 9 Writer Usage .....</b>	<b>46</b>
Preparation before Programming .....	46
Case. 1 – Using External Digital Signals to Control e-WriterPro/e-WriterPro2 Programming .....	46
Case. 2 – Using External Digital Signals to Control Gang-Writer00-8 Programming .....	48

Case. 3 – Using the e-WriterPro In-circuit Programing Function ..... 49

Case. 4 – Using the e-WriterPro2 In-circuit Programing Function ..... 50

**Appendix ..... 52**

Appendix A e-WriterPro/e-WriterPro2 CN3 Pin Definitions ..... 52

Appendix B e-WriterPro ICP Pin Definitions and ICP Considerations..... 52

Appendix C e-WriterPro/e-WriterPro2 LED Status Description..... 58

Appendix D Writer Messages..... 58

Appendix E e-WriterPro2 ICP Pin Definitions..... 60

Appendix F Gang-Writer00-8 LED Status Description ..... 61

Appendix G Gang-Writer00-8 Module Board Interface Pin Introduce ..... 62

## Chapter 1 Software Introduction

### General Description

The HOPE5000 is a software designed by Holtek for programming MCUs, which must be used together with Holtek’s Writer (e.g. e-WriterPro, e-WriterPro2, etc.). The software is connected to the writer via a USB cable to transmit the related programming data.

### Software Download

Download the HOPE5000 software from the Holtek website: <https://www.holtek.com>.

### Software Installation

Execute the installing program “HOPE5000 Setup.exe”:

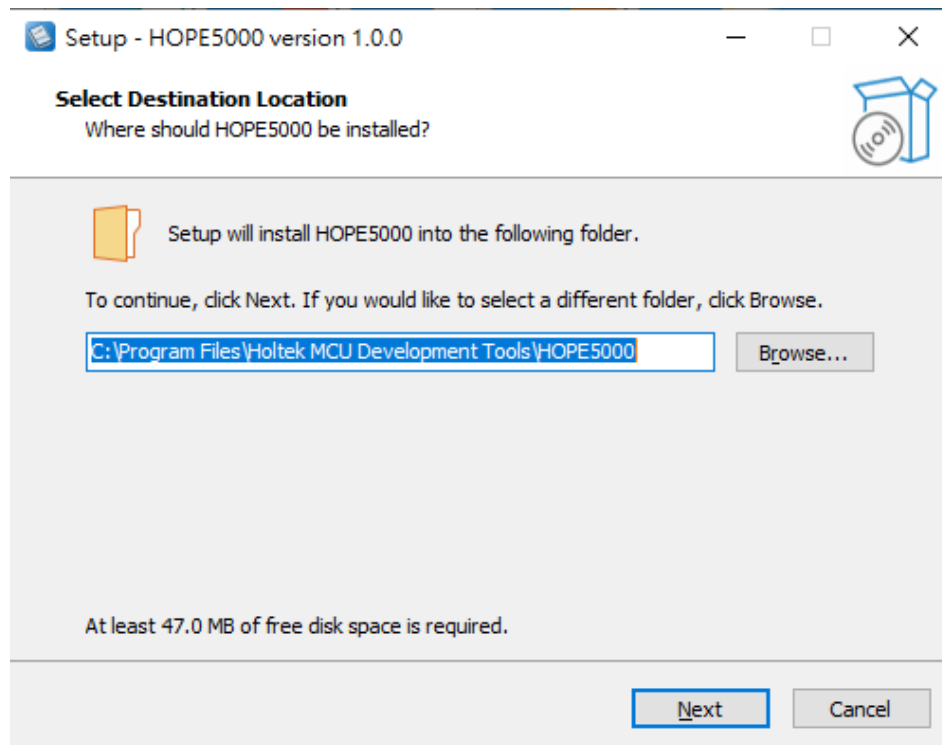

Then following the instructions to install until the installation is completed.

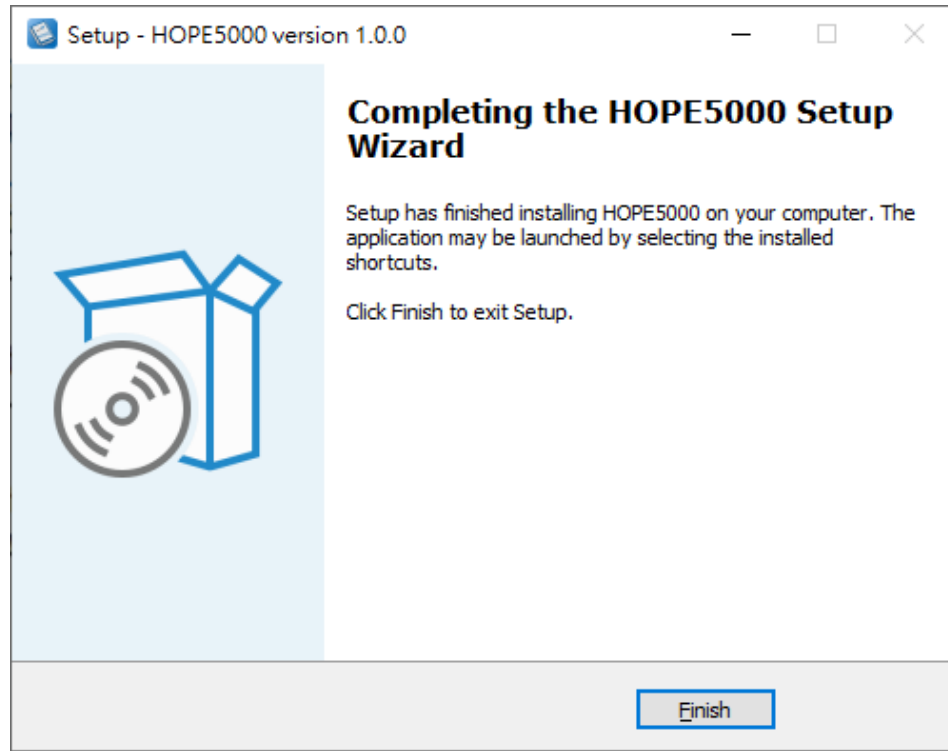

**System Requirement**

The software can be executed on the Microsoft Windows. The operating environment requirement is that the original version of Microsoft Windows has been installed (Windows 10 and above).

## Chapter 2 Function Introduction

This chapter will describe the HOPE5000 software interfaces and functions.

### File

In the file function page, users can execute the open, save and save as operations to the programming file (the programming file should be generated by the MCU development tool software).

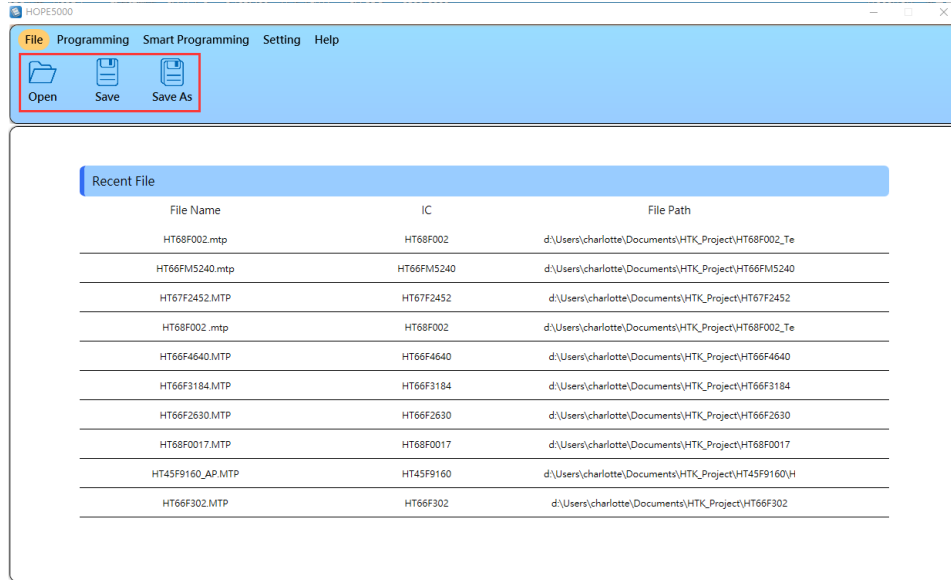

1. Open:  
Open the file to be programmed, or click the programming file recorded in the Recent file directly.
2. Save:  
Save the opened programming file (It is usually used to store the smart programming settings).
3. Save as:  
Save as the opened programming file as a new programming file.

## Programming

In the programming function page, users can execute the Program, Erase, Blank Check, Verify, Lock and Read MCU operations. In addition, on the left side of this page information such as programming file information, writer settings and execution results will be displayed, on the right side, data to be programmed to the MCU also will be displayed, and the version information of the software and hardware will be displayed at the bottom.

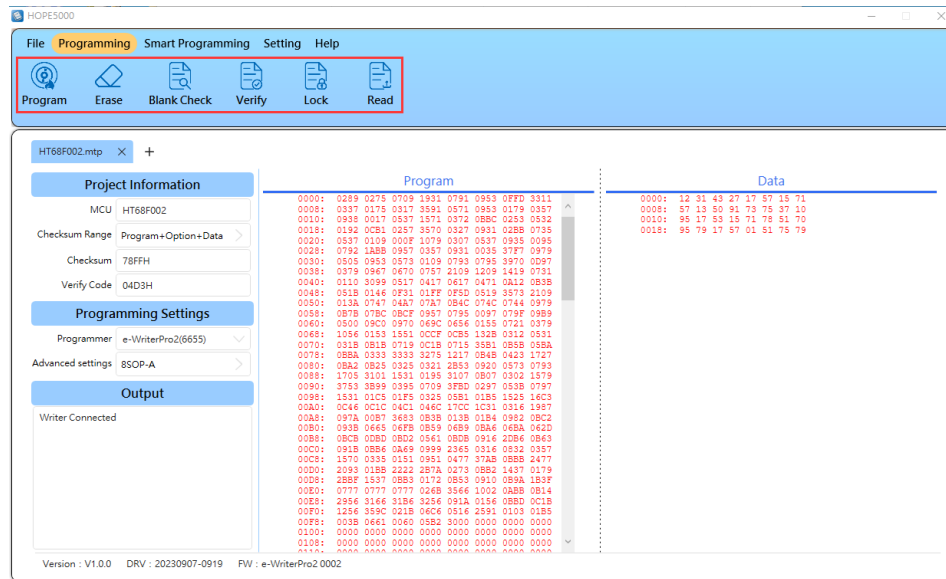

### 1. Program:

Program the opened programming file to the MCU.

### 2. Erase:

Erase the data in the MCU to make a blank MCU. (The OTP type MCUs are not supported in this operation).

### 3. Blank Check:

Check whether the connected MCU is empty.

### 4. Verify:

Check whether the data in the programming file is the same as that the MCU in the writer.

### 5. Lock:

Lock the MCU to prevent the programmed data in the MCU from being read out. This function is used to protect the MCU data.

### 6. Read:

Read the programmed data in the MCU and display it on the software interface.

## Smart Programming

In the smart programming page, users are allowed to execute a customization for the writer programming operation settings. The smart programming page contains five function buttons.

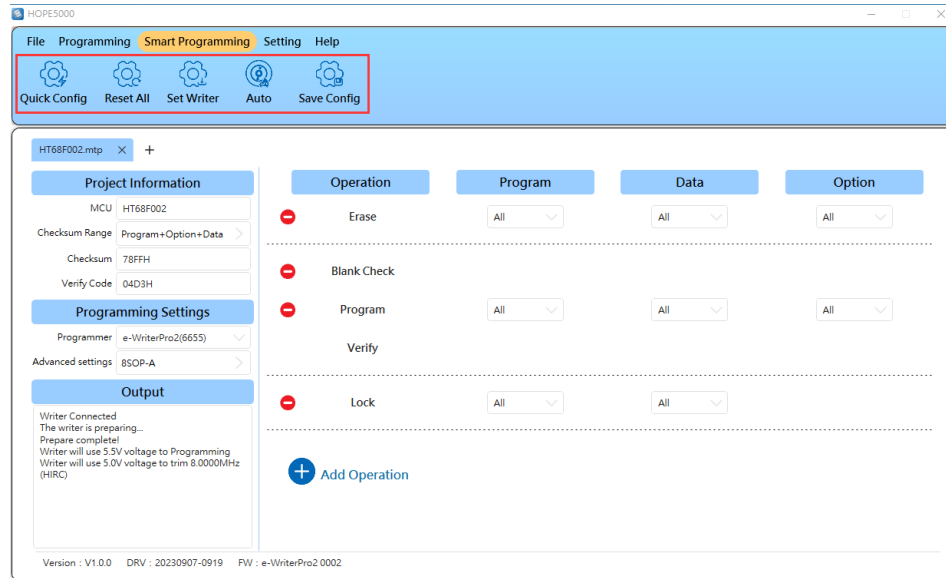

### 1. Quick Config

Configure the Program, Verify and Lock operations directly.

### 2. Reset All

Restore all the settings on the Smart Programming UI to the default settings.

### 3. Set Writer

Download the programming settings in the writer.

### 4. Auto

Execute the programming operations set on the Smart Programming UI (The download settings must be executed before using this function).

### 5. Save Config

Save all the settings on the Smart Programming UI in the programming file.

The smart programming detailed settings are described in Chapter 4.

## Setting

The Setting page allows users to configure the Writer and the MCU.

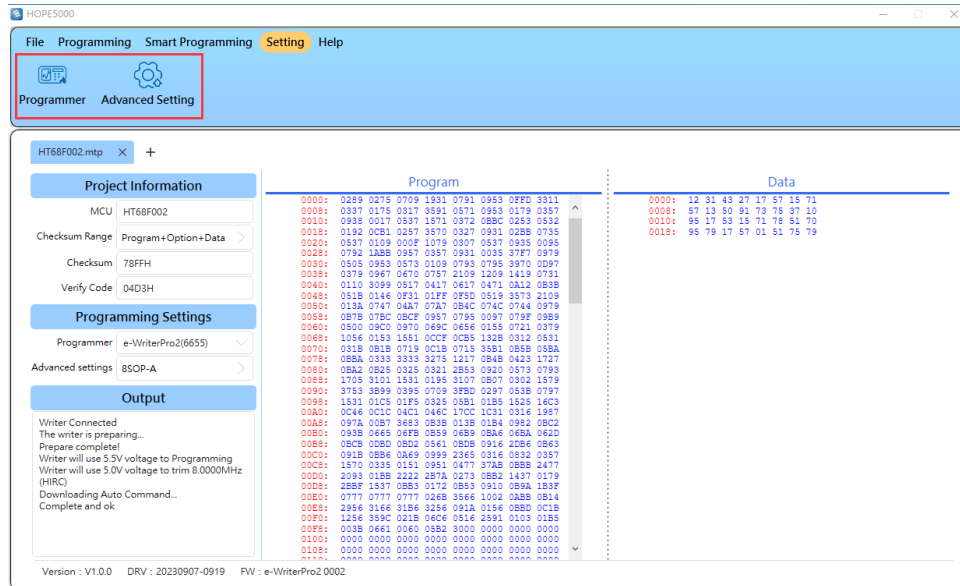

### 1. Writer

- a. F/W Update: Update the firmware of the writer.
- b. Buzzer Setting: Set the buzzer volume produced by the writer.
- c. Reset Writer: Clear all programmed file information on the writer.
- d. Without prompt when the F/W is updated: After this option is selected, when the Smart Programming Setting is being downloaded or the MCU is being operated, if the software detects that the writer F/W needs to be updated, it will update the F/W without generating a prompt to users.

Here the setting items are different according to the writer type selected by users (e-WriterPro or e-WriterPro2, etc.).

### 2. Advanced Setting

- a. Read the locked IC's information: Used to obtain the locked MCU's checksum and verify code.
- b. Modify the programming data: Allow users to modify the programming file original data.
- c. Start the identifier code: Allow users to program a user-defined data to the MCU as its identification or other purposes.

## Help

Other settings can be implemented here.

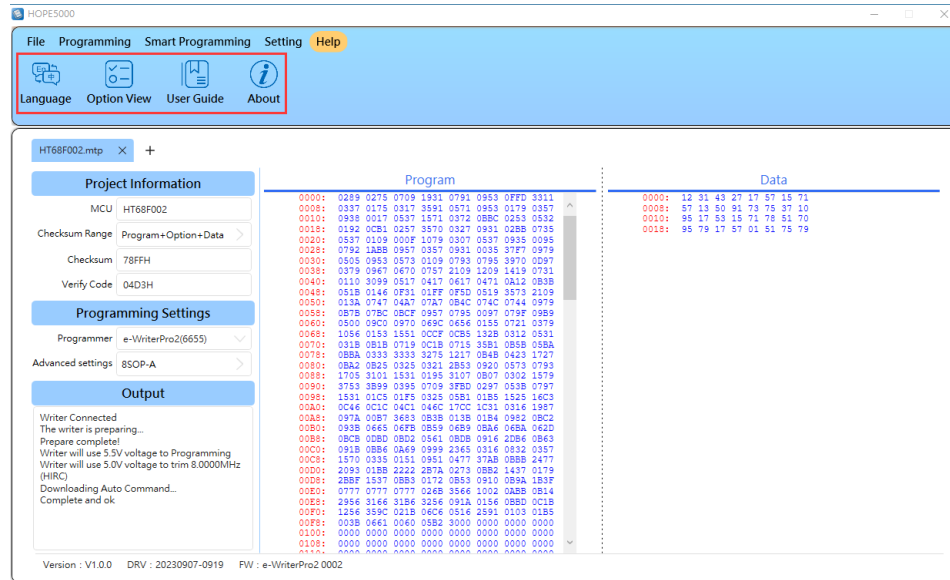

### 1. Language

The UI language can be switched to Simplified Chinese, Traditional Chinese and English.

### 2. Option Viewer:

Preview the advanced information of the programming file. The premise is that the HT-IDE3000 has been installed.

### 3. User Guide:

View the software and the relevant instructions for the writer.

### 4. About:

Show the version information of the software and hardware.

## Advanced Function

### Open the Multiple File Function

The HOPE5000 supports multiple programming files to be opened simultaneously, click the button “+” to open a new programming file.

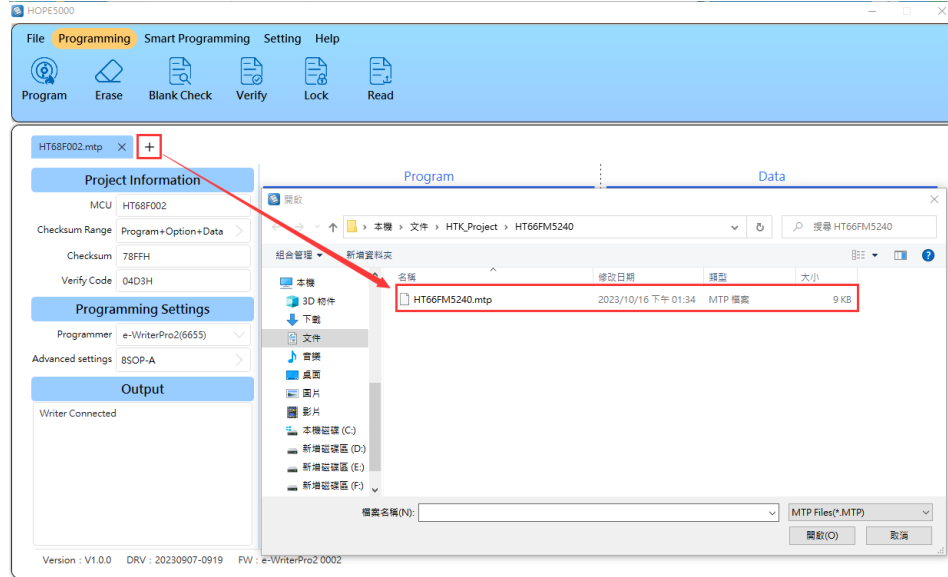

After more than two programming files have been opened successfully, users can switch them between different programming files.

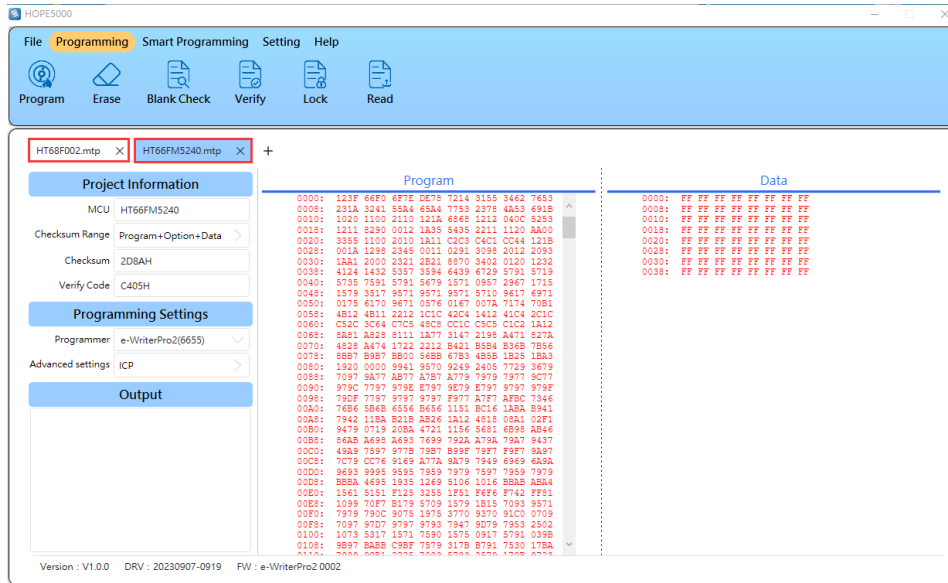

## Chapter 3 Programming MCU

This chapter will describe the detailed steps from how to open a programming file to actually programming an MCU.

### Load Programming File

Execute the “HOPE5000.exe” to enter the file function page first, then click the button “Open” to select the programming file to be loaded. Finally open the file.

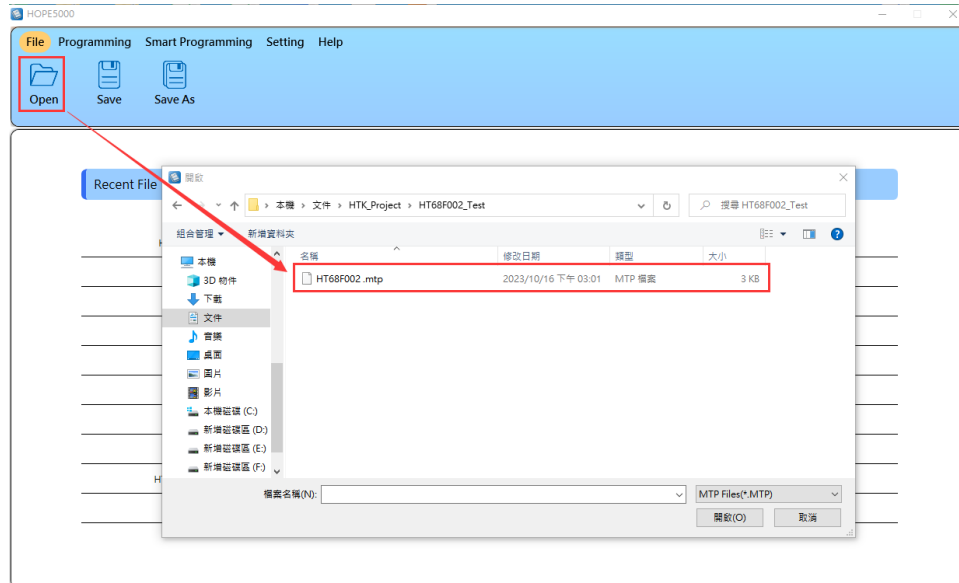

The programming file that has been loaded successfully will be recorded in the “Recent File”. To open this file again in the future, users can directly use the mouse to double-click the programming file to load.

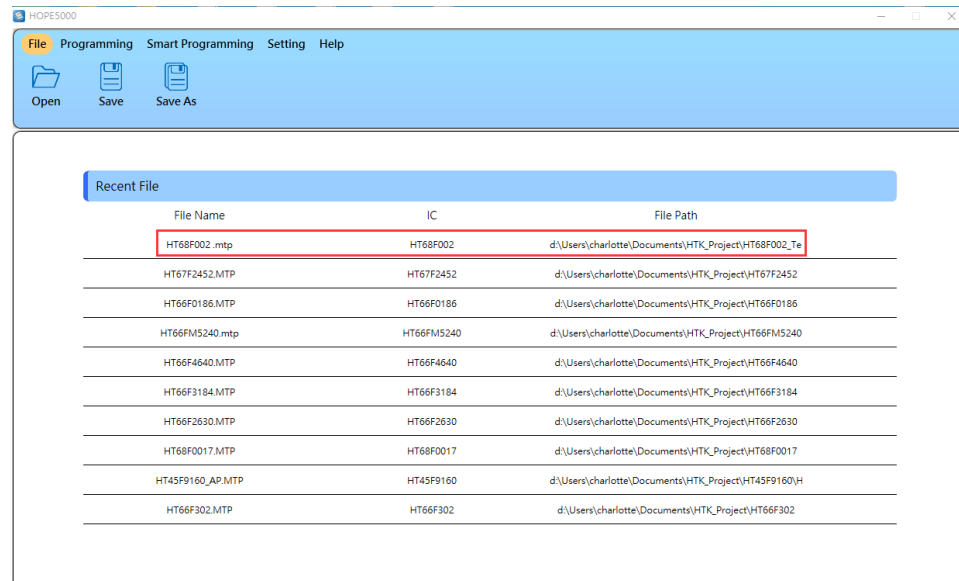

After the programming file has been opened successfully, the interface will switch to the programming function page. The page will display the MCU name, Checksum, Verify Code and related programming information of the programming file.

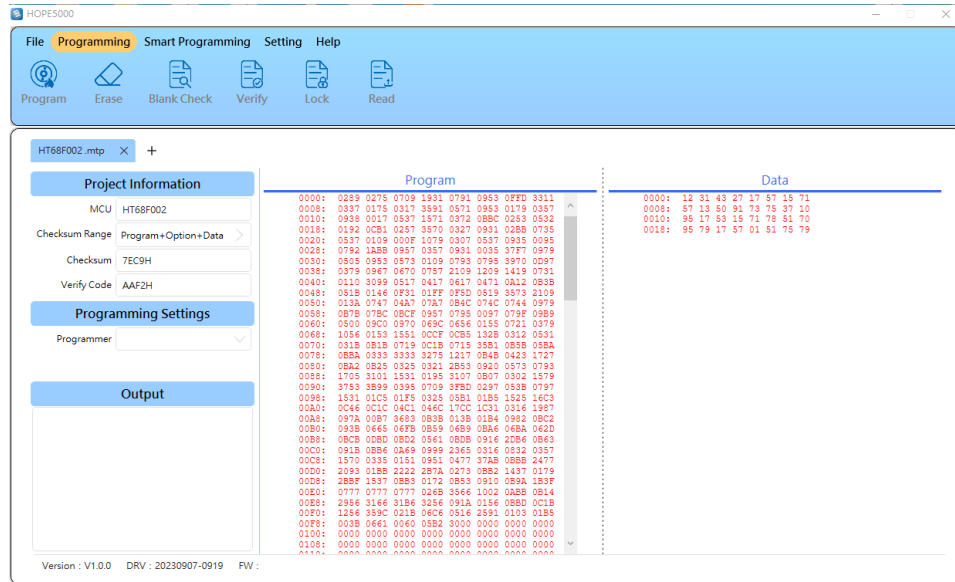

### Programming Settings

Use a USB cable to connect the computer to the Writer (e.g. e-WriterPro2), and the corresponding information will be displayed on the “Programming Settings” and “Output” sections.

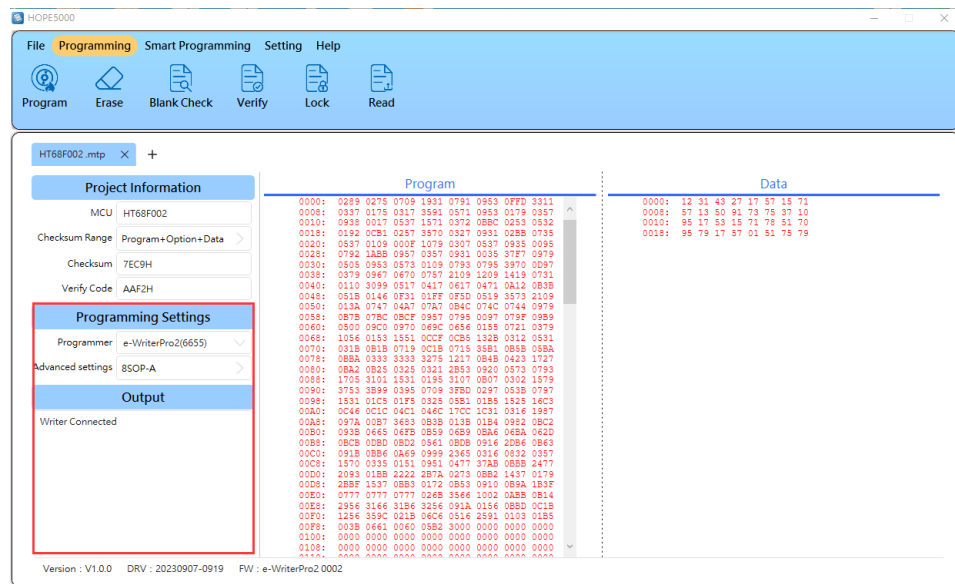

On the “Programming Settings” side, it shows the current connected writer type and ID. Then click “Advanced settings” to set according to how the MCU is actually connected to the writer.

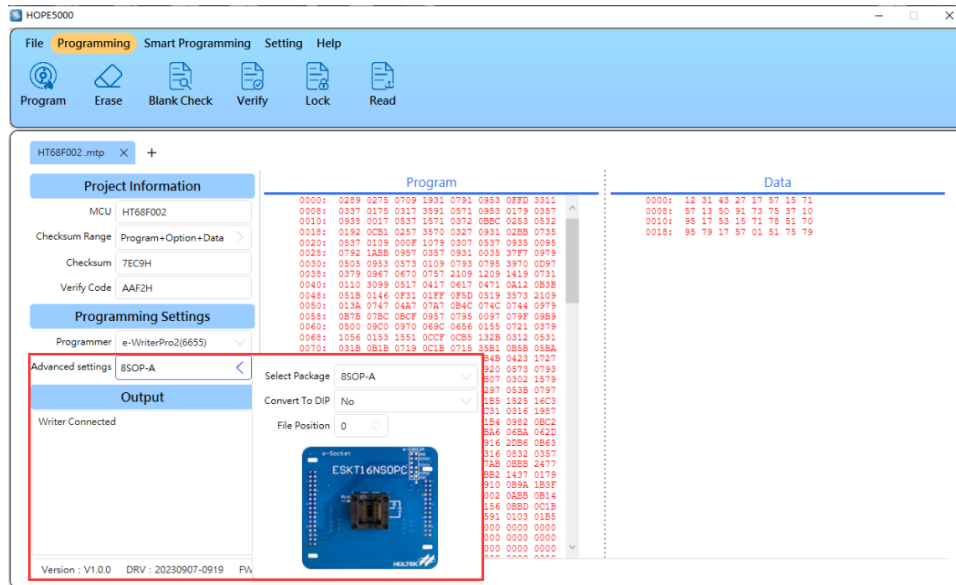

The “File Position” function is only available when a writer has been selected that supports multiple files. This function is further explained in the next section.

### Download Multiple File Function

If the writer selected by the user has multiple file function (e.g. e-WriterPro2), when the programming setting is executed, the “File Position” setting will then pop up. This function allows users to store up to 30 programming files simultaneously in the same writer (the file position number starts from 0 to 29).

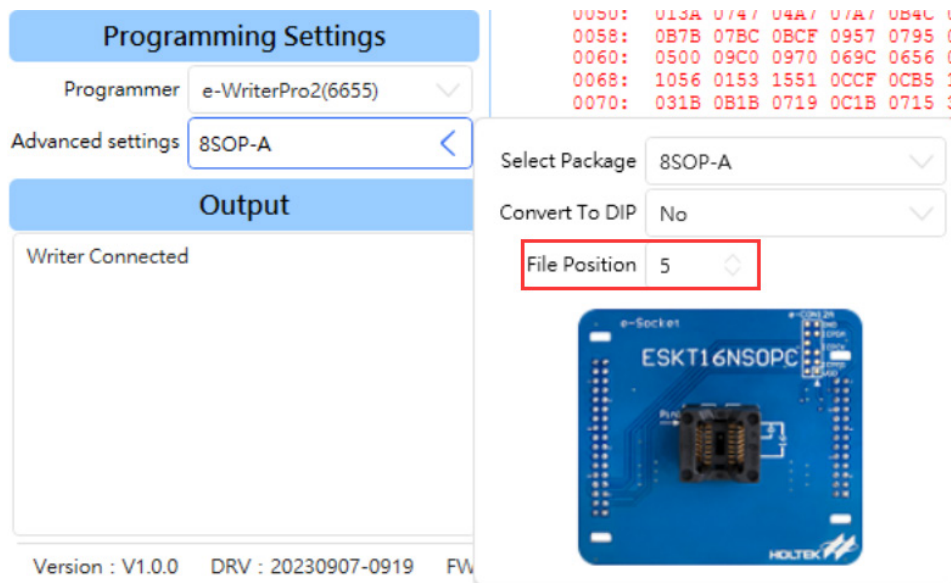

After all settings are completed and the programming data is downloaded to the writer, users can switch between different programming file positions on the writer directly.

Note that when updating the firmware on a writer that supports multiple files, for the programming

files that have been downloaded to the writer, it may become unusable after the writer firmware is updated. (For example, when updating the writer firmware from a new version to an older version, it may occur that the writer cannot use the programming file position of the downloaded new MCU).

### Executing the Programming Operation

After setting the writer, users can click the function button on the programming page to operate the MCU directly.

#### Program

Click “Program” button first, this function can program the data of the programming file to the MCU.

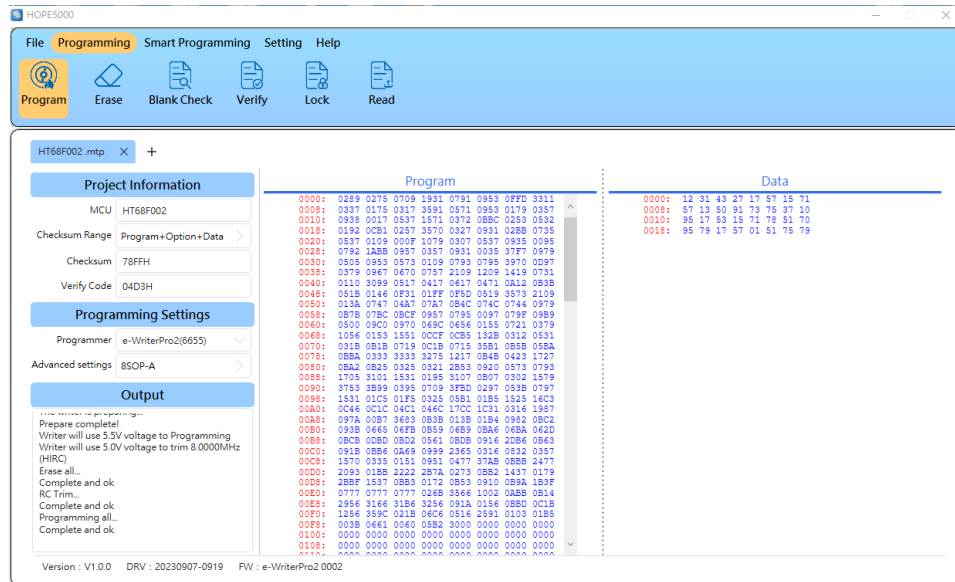

#### Verify

After the MCU has been programmed, click the “Verify” function to verify whether the data in the MCU is consistent with the programming file.

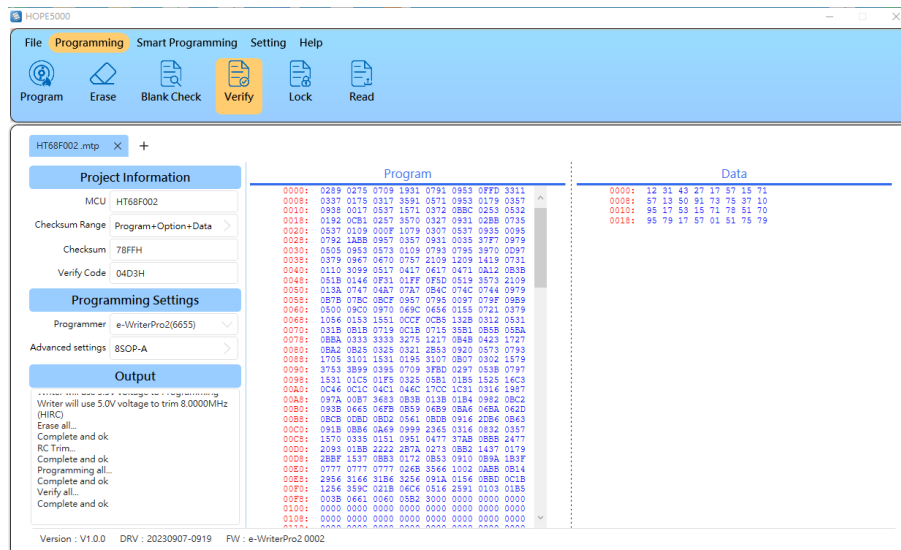

## Lock

Click “Lock” to lock the MCU. This operation can prevent the data in the MCU from being read out and protect the MCU programmed data.

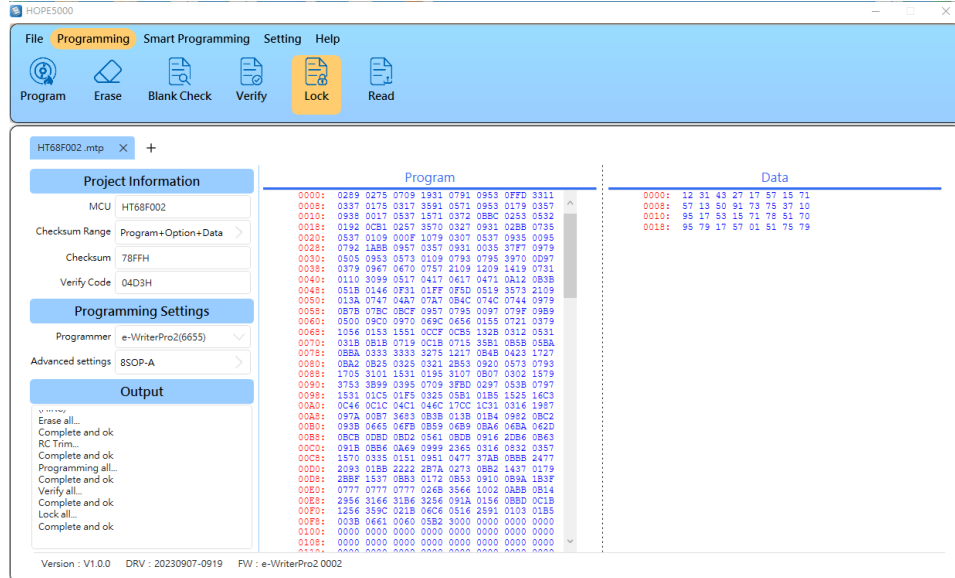

The locked MCU will not be executed such as blank check and verify.

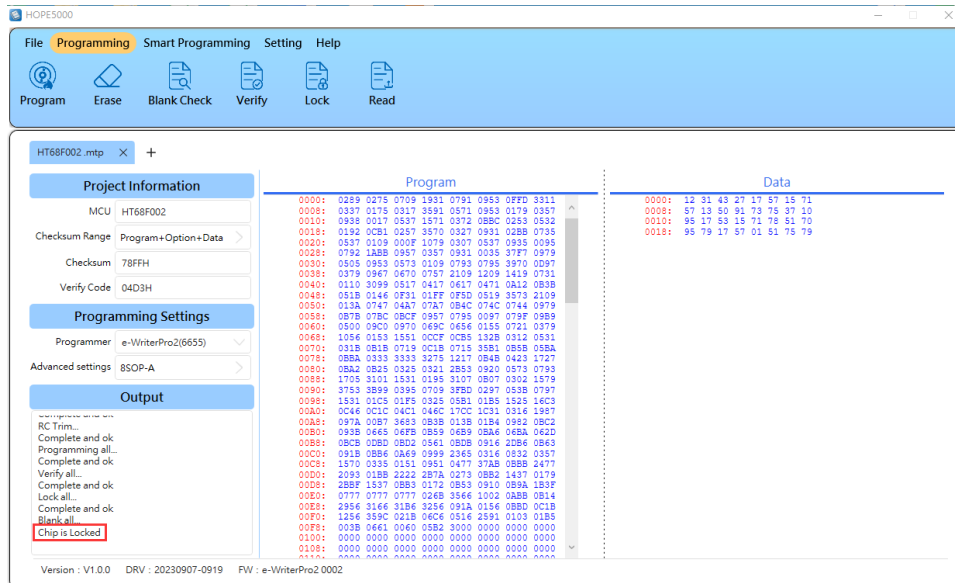

### Erase

Click “Erase” to clear the data in the MCU and make a blank MCU. (The OTP type MCUs are not supported in this operation).

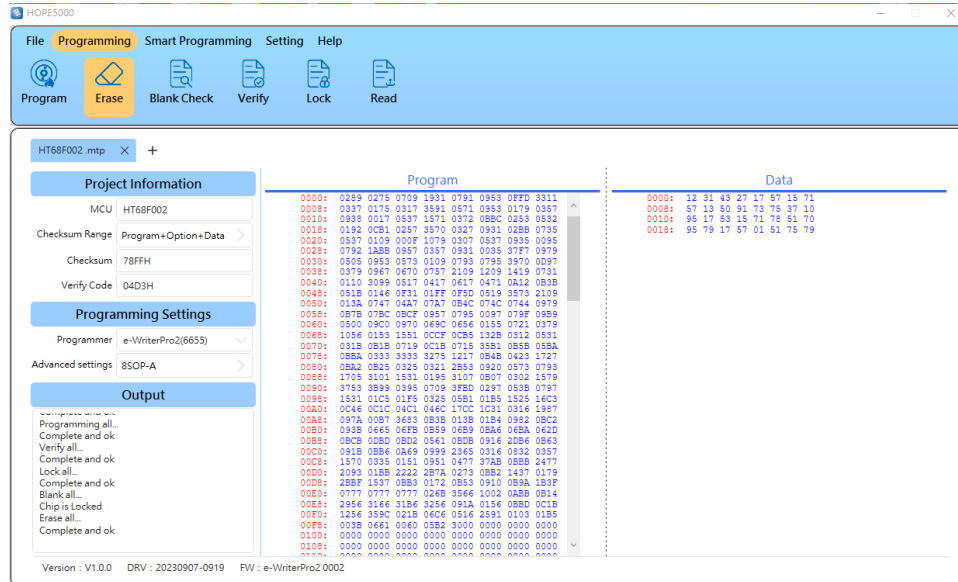

### Blank Check

After the erase has been completed, click “Blank Check” function to check whether the MCU has been cleared successfully (that is, whether the MCU is empty).

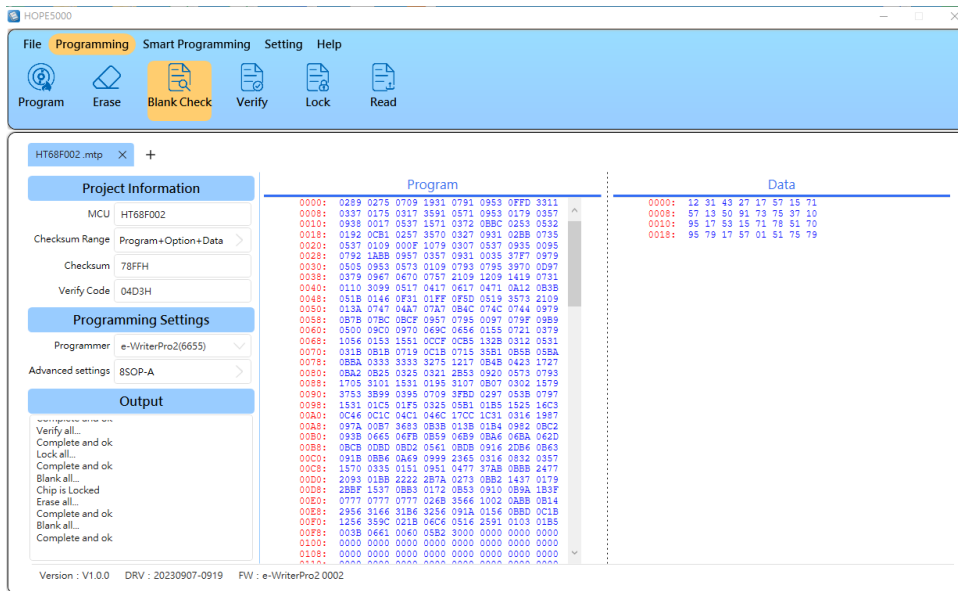

### Read

The read function can read back the programming data in the MCU and display it on the software interface.

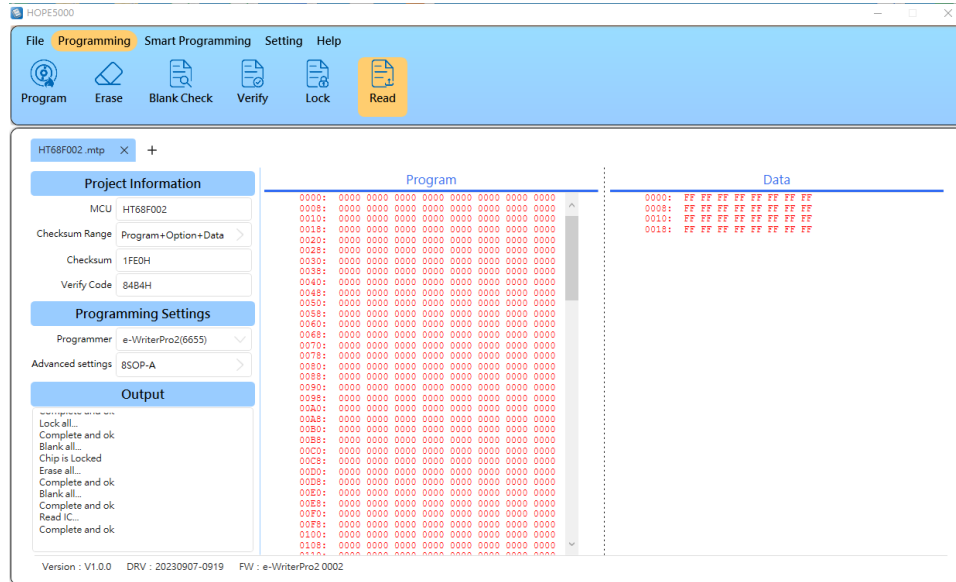

Since the erase operation has been executed, the MCU programming information at this time is displayed as an empty state.

## Chapter 4 Offline Programming Function

By setting the smart programming function, users are allowed to execute the preset programming operations on the MCU when the writer is not connected to the computer. This chapter will introduce how to use the smart programming function to set the writer offline programming function.

### Smart Programming Function Configuration

Enter the “Smart Programming” function page, click the button “+” to add a new operation.

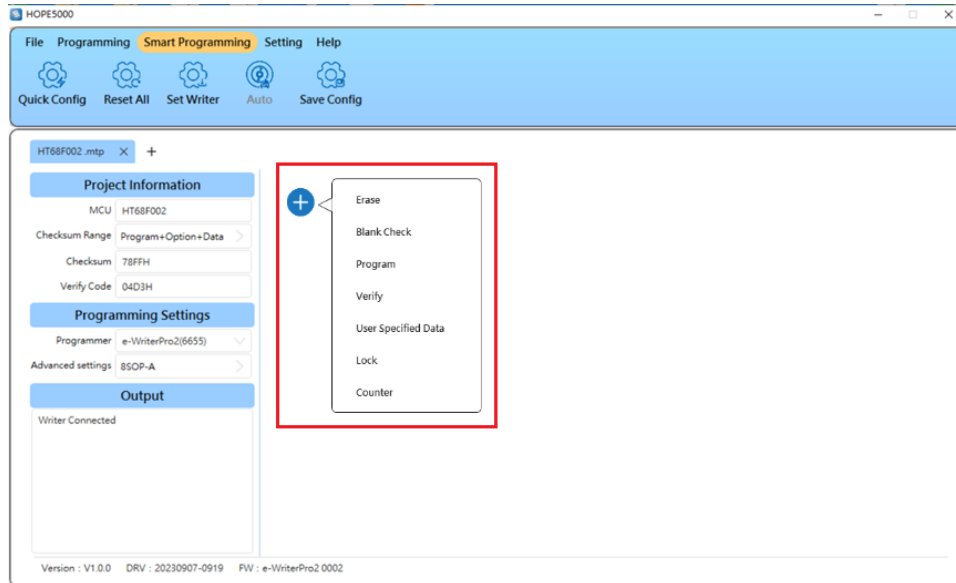

There are seven functions as shown in this interface, such as “Erase”, “Blank Check”, “Program”, “Verify”, “User Specified Data”, “Lock” and “Counter”, users are allowed to combine these programming operations freely.

### Programming Operations Configuration

Now try to add the operations of “Erase”, “Blank Check”, “Program”, “Verify” and “Lock” in sequence.

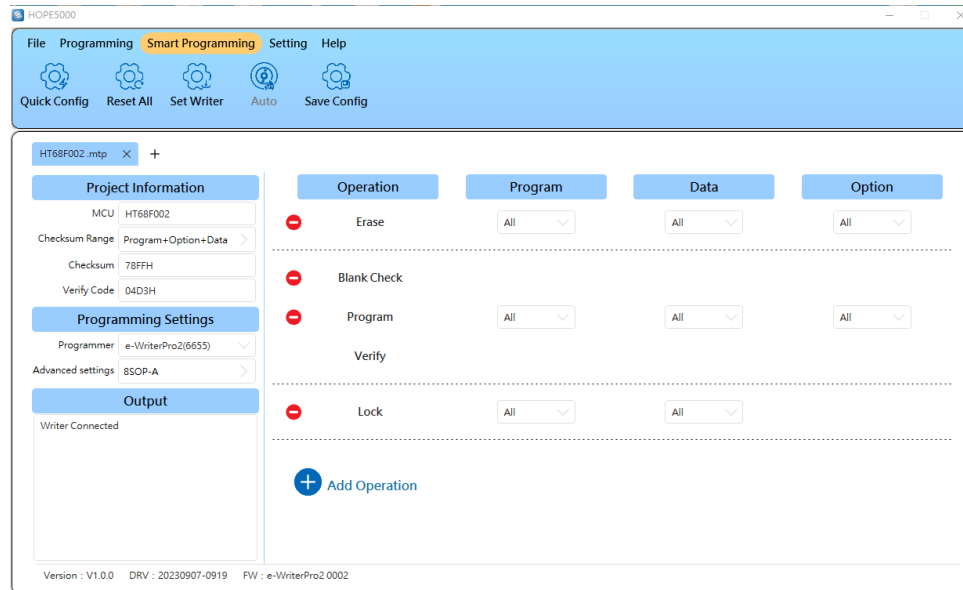

To remove a programming operation that has already been set, click the button “-” in front of the operation to delete. In addition, the HOPE5000 also provides a one-click setting function for quick setting, which will automatically configure the operations of program, verify and lock after clicking. To delete all smart programming settings, click “Reset All” to clear all settings.

### Set Writer and Auto Programming

After the smart programming setting is completed, click the button “Set Writer” to download all settings to the writer.

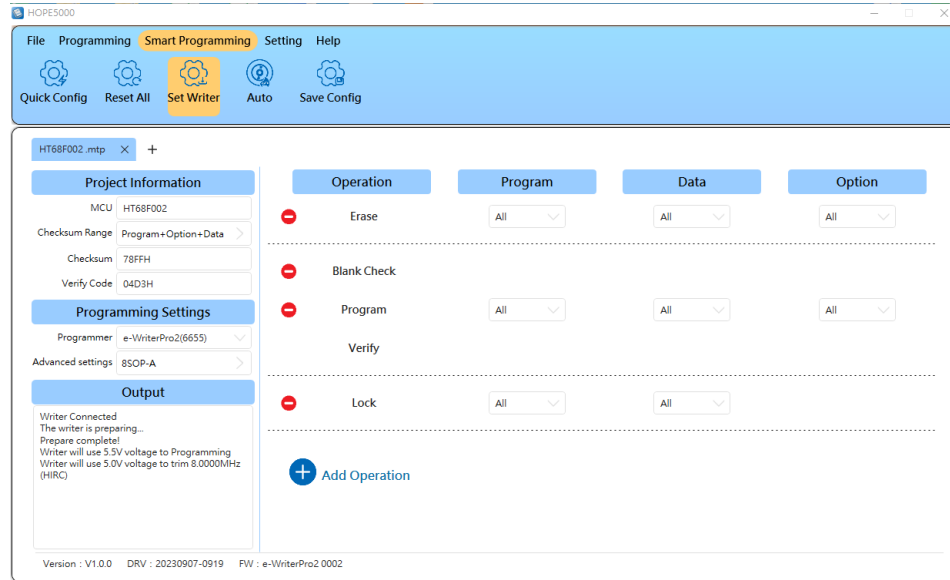

After setting, click the button “Auto”, the writer will execute the smart programming operation set by the user.

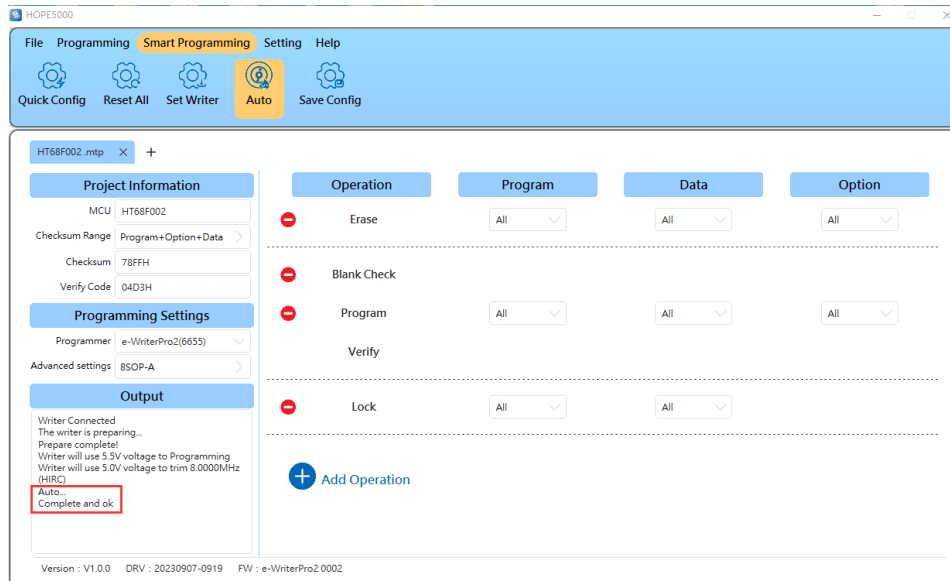

### Offline Programming Usage

For offline programming function which means to operate the writer without connecting it to a PC, it is necessary to complete the smart programming setting on the HOPE5000, then connect to the writer and click “Set Writer”. After pressing the red programming key on the writer, users can execute the smart programming operation. Take the e-WriterPro2 as an example.



### Advanced Function

For the applications, if user need to execute erase, program or lock certain data blocks on the MCU, this goal can be achieved by the “Partial Erase”, “Partial Programming”, “Partial Lock” and “Programming User Specified Data” of the smart programming functions.

#### Partial Erase

The partial erase function is carried out in a page format (the page size of each MCU is not the same). The following is an example of erasing the 0th Page of the Program Memory.

Step 1: Enter the “Smart Programming” interface, click “Add Operation” to add the Erase function.

Step 2: For the erase setting, change the Program setting to “Range” and click the rear setting button.

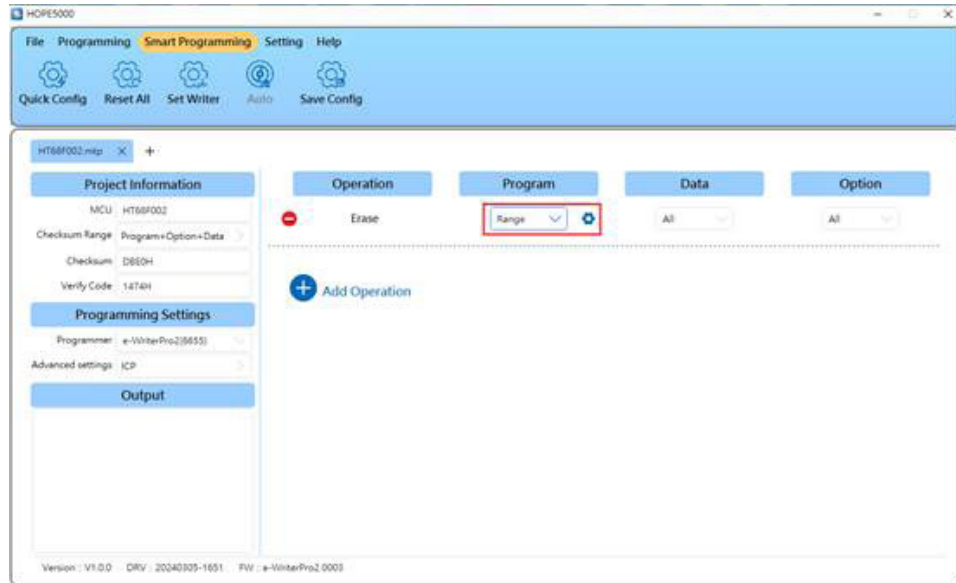

Step 3: In the “Partial Erase” setting interface, it will display all page settings that can be erased in this MCU. Click “Page 0” and the Program Memory on the left will show the range to be erased in red.

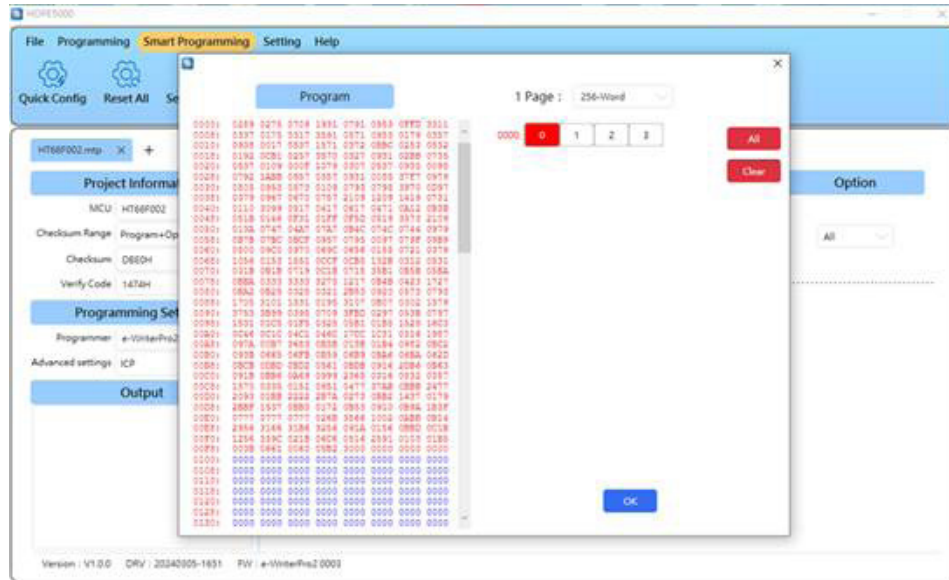

Step 4: Click “OK” to complete the setting, and click “Set Writer” and “Auto” on the Smart Programming interface to erase Page 0 of the Program Memory.

### Partial Programming

The partial programming function is carried out in a page format (the page size of each MCU is not the same). Add a programming operation on the Smart Programming interface before setting.

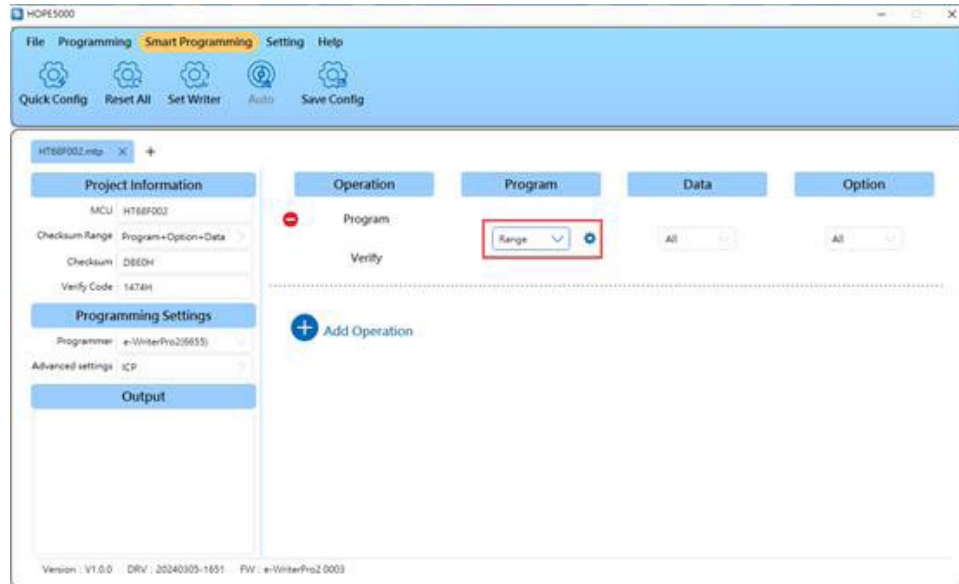

The subsequent setting method is the same as the Partial Erase. Refer to the “Partial Erase” setting in the previous section.

### Partial Lock

The Partial Lock function needs to lock several pages at a time (each MCU setting is not the same). Take the Program Memory Page 0 ~ 1 (2 Pages) to be locked as an example.

Step 1: Add a “Lock” operation on the smart programming interface, change the Program setting to “Range” and click the rear setting button.

Step 2: In the “Partial Lock” setting interface, it will display the MCU partial lock settings. Click the button “0~1” and the Program Memory on the left will show the locked range in red.

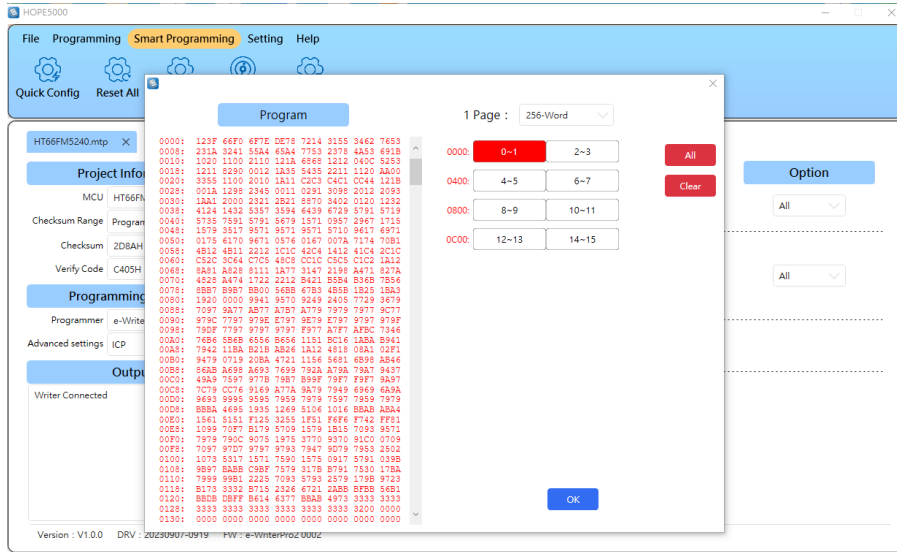

Step 3: Click “OK” to complete the setting, and click “Set Writer” and “Auto” on the smart programming interface to execute the lock operation to Program Memory Page 0~1.

### User Specified Data

The user specified data function allows users to write specific values at specified positions in the Program Memory and EEPROM. The following will introduce how to write a user specified value in the Program Memory. First add a user specified operation on the smart programming interface, and then change the Program setting to “Use” and click the rear setting button.

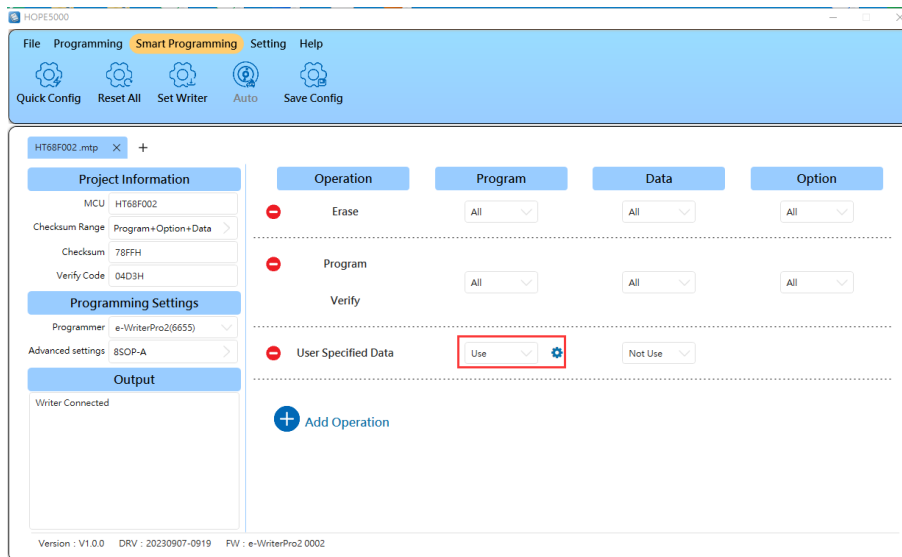

The user specified data can be used in two methods:

## 1. Expression:

To program each MCU by the writer, the user specified value will be increased (or decreased) by N automatically. Assume that users want to program the digital 74565 at the start address F00H in the Program Memory, and then increment it by 1, the setting is shown as follows:

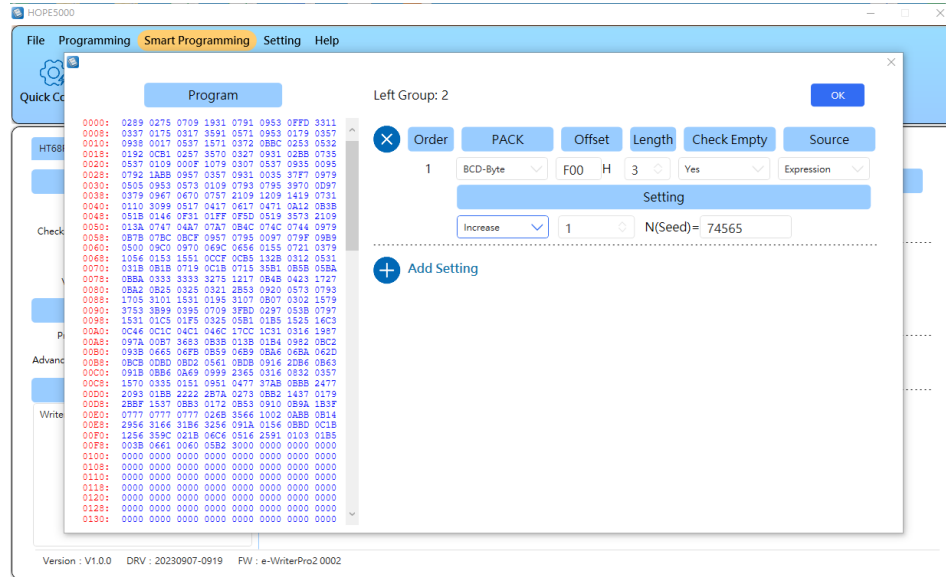

The PACK settings provide four different forms for the programming values. Taking the programming data of 74565 (12345H) as an example:

Form	Program ROM Address	F00H	F01H	F02H
Binary-Byte		0045	0023	0001
BCD-Byte		0065	0045	0007
Binary-Word		2345	0001	0000
BCD-Word		4565	0007	0000

The PACK type settings are selected by user.

Add another two points:

- If the length is not set enough, the part with a length longer than that will be discarded.
- Note that the program does not detect an “N+1” overflow or an “N-1” underflow.

## 2. Preload File:

Each time the writer programs an MCU, the user specified data will jump to the next record in the configuration file. Assume that users have three data records in the SN.txt file.

12345H

111110000B

47219

Then according to the setting of SN.txt file to program the serial number from the start address F00H of the Program Memory. The source setting is changed to “Preload File”, and click “Open File” to select the SN.txt position.

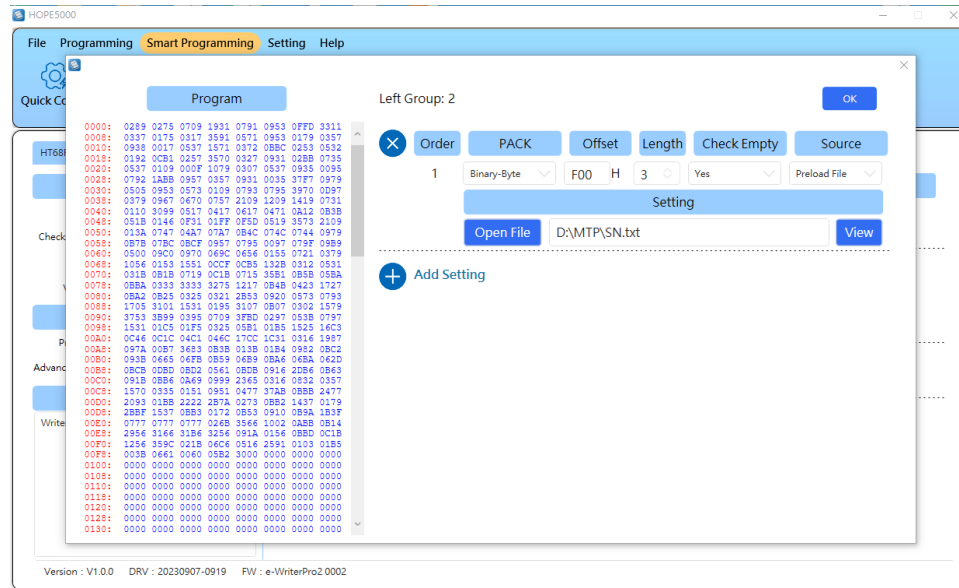

After the file has been opened successfully, the following preview window will be displayed:

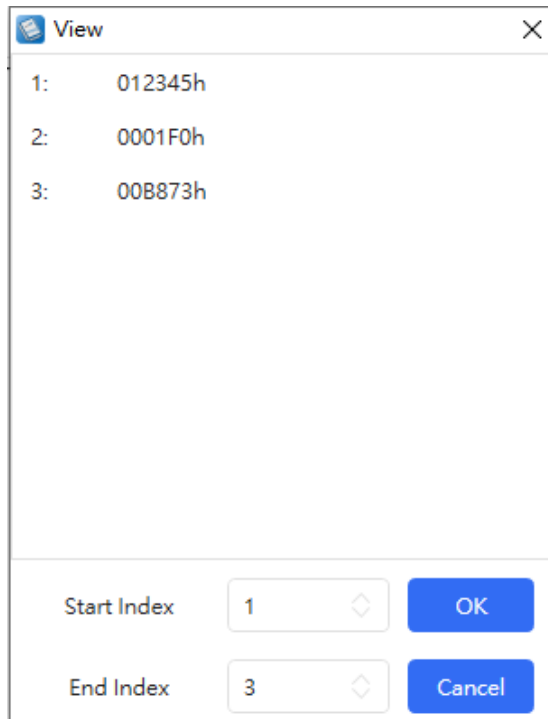

Click the button “OK” to complete the setting of loading values from the file.

In addition, the file format also supports “.BIN” - binary file. For example, if the data in a .BIN file is: 12 34 56 78 9A BC CD and the specified data length is 3 bytes. Then the 1st record of data is 563412H, the 2nd record of data is BC9A78H, the 3rd record of data is 0000CDH (fill in 0 for the insufficient part of 3 bytes).

After the user specified data setting is completed, click “OK” to complete the setting, and then click “Set Writer” and “Auto” on the smart programming interface to program the user specified data into the Program Memory.

### Counter

The counter function allows users to set the maximum times of the offline programming. When the programming operation limit is reached, it is necessary to re-download the programming data, otherwise it will not be able to continue the offline programming operation.

The counter function is set as follows:

Step 1: Enter the “Smart Programming” interface, click “Add Operation” to add the counter function.

Step 2: Modify the counter (default to 100, the minimum programming times is 1).

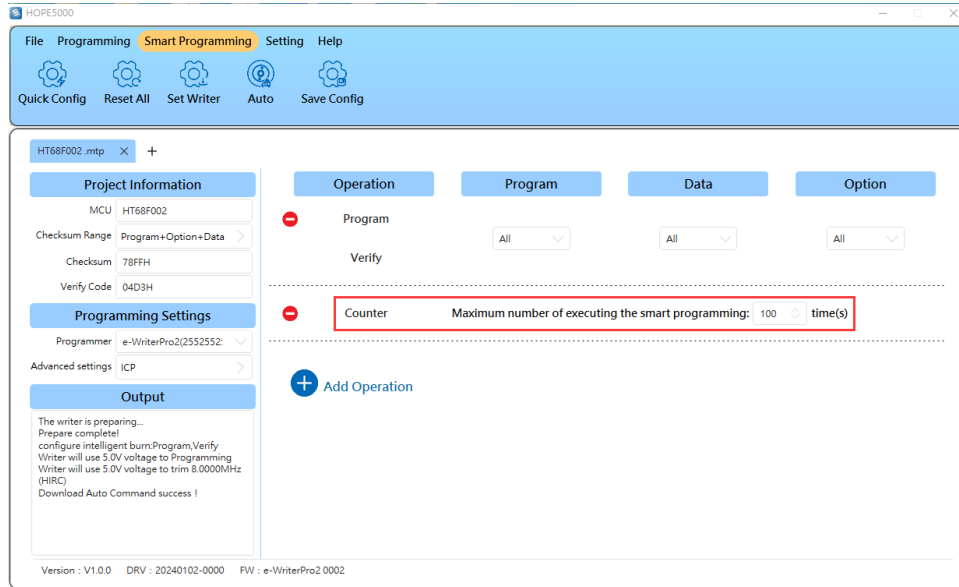

There are two points to note when using the counter function. First, this function should be configured with the programming function, and should not be used independently. Second, it needs to be used with a writer that supports the counter function (e.g. e-WriterPro2).

After the counter function setting is completed, click the “Set Writer” on the smart programming interface to complete the counter function setting.

## Chapter 5 HOPE5000 Supported Writer

Currently, the HOPE5000 supports the writers of e-WriterPro, e-WriterPro2 and Gang-Writer00-8. The hardware functions are compared as follows.

Item	Writer	e-WriterPro	e-WriterPro2	Gang-Writer00-8
Multiple file function		Not supported	Supported (30)	Not supported
Supported MCU types		MTP & OTP MCU	MTP & OTP MCU	Only support MTP MCU
Supported programming methods		e-Socket & ICP ((e-CON12A) and ICP(e-CON12C))	e-Socket & ICP (only have a ICP, the slot is on top of CN2)	Only support ICP
The number of MCUs that can be programmed at one time		1	1	A module board can be programmed a maximum of 4 MCUs, and a base board can be connected to a maximum of 4 modules, therefore a maximum of 16 MCUs can be programmed at one time
Online – auto programming function		Supported	Supported	Not supported
Buzzer volume		Set by software	Set by LCD with ADJ and Set keys	The base board is set by LCD with ADJ and Set keys
LCD brightness		Cannot be adjusted	Set by LCD with ADJ and Set keys	The base board is set by LCD with ADJ and Set keys
The language of the message		English only	Support English, Simplified Chinese and Traditional Chinese, set by LCD with ADJ and SET keys	Support English, Simplified Chinese and Traditional Chinese, the base board is set by LCD with ADJ and Set keys

## Chapter 6 e-WriterPro Introduction

### Introduction

The e-WriterPro is a writer designed for programming the Holtek all series of MCUs. The writer can be used to write program or data to all the OTP/Flash MCUs designed by Holtek. The writer's special features are in its small, light and handy palm size outline. Installation is simple and is easy to use.

This writer supports an online programming mode that needs to connect with a PC and an offline programming mode that does not require a PC connection. In the offline mode, after downloading the programming data to the writer using the HOPE5000 on a PC, the writer can be operated without a PC connection. In the online mode, a USB cable is required to connect to the PC and the writer after which the writer can be operated using the HOPE5000.

As Holtek provides different MCU package types, different programming sockets, i.g. e-Socket, are also supplied for programming different MCU package types.

### Installation

#### System Requirement

To use the writer the following device and system are required:

- Power: Use the power adapter included in the product box in Offline Mode, as shown in the table below.

Writer Connector	e-WriterPro	Remark
USB Connector	Supported	Using a power adapter with 5V output voltage and at least 500mA output current. It is suggested to use the power adapter supplied by Holtek.

- Correct programming socket
- PC with a USB port for online mode
- HOPE5000 software for online mode

Note: Programming sockets are consumables, it is suggested to maintain and update them regularly.

#### Package Contents



Item	Content Name	Count
1	e-WriterPro	1
2	USB Cable	1
3	5V USB Power Adapter	1
4	1.5m Ground Wire	1
5	Flat-Cable double-head 2×6 Pin Connector (25cm)	1
6	Screws (with G15 ground terminal)	1
7	Important Information Card	1

### Hardware Installation

Connect the e-WriterPro to the PC USB port using the USB cable.

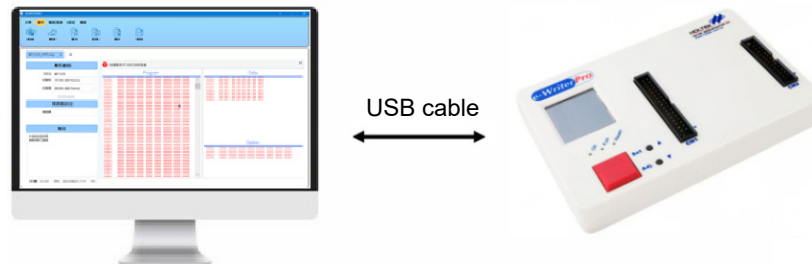

### Hardware Configuration

The name of each writer hardware section and detail explanation are shown in the following figure.

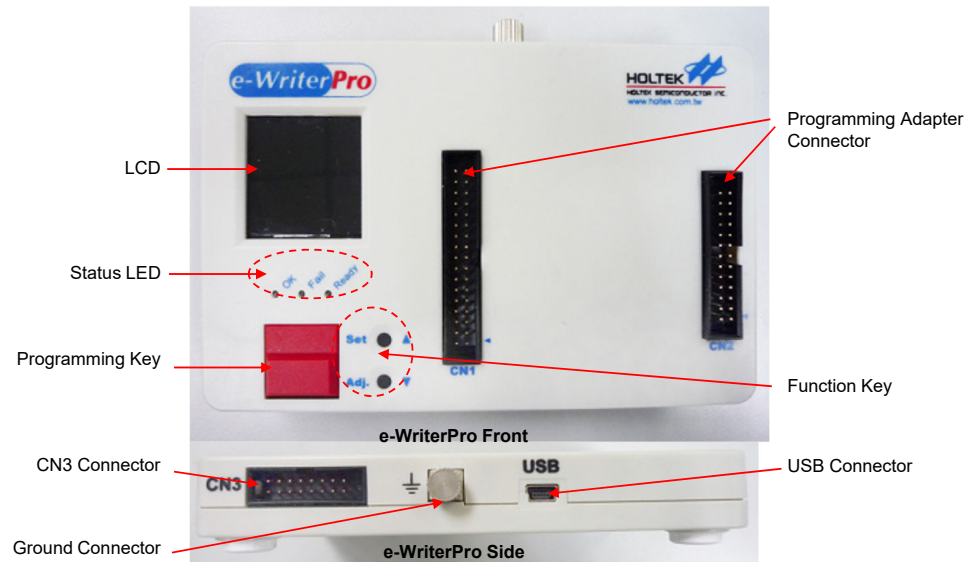

<b>Item</b>	<b>Explanation</b>
Programming Adapter Connector	Programming Pins
OK	Normal Status LED
Ready/Busy	Ready or Busy Status LED
Fail	Fail Status LED
Programming Key	Offline Mode Programming Key
USB Connector	Connect to PC via USB cable (online mode) or Connect to 5V power adapter (offline mode)
LCD	Displays information and to set the writer functions
Function Key	Switch LED pages and to set the writer functions
CN3 Connector	External control signal interface, refer to Appendix A
Ground Connector	Connector for ground wire

## Chapter 7 e-WriterPro2 Introduction

### Introduction

The e-WriterPro2 is a writer designed for programming the Holtek all series of MCUs. The writer can be used to write program or data to all the OTP/Flash MCUs designed by Holtek. The writer's special features are in its small, light and handy palm size outline. Installation is simple and is easy to use.

This writer supports an online programming mode that needs to connect with a PC and an offline programming mode that does not require a PC connection. In the offline mode, after downloading the programming data to the writer using the HOPE5000 on a PC, the writer can be operated without a PC connection. In the online mode, a USB cable is required to connect to the PC and the writer after which the writer can be operated using the HOPE5000.

As Holtek provides different MCU package types, different programming sockets, i.g. e-Socket, are also supplied for programming different MCU package types.

### Installation

#### System Requirement

To use the writer the following device and system are required:

- Power: Use the power adapter included in the product box in offline mode
- Correct programming socket
- PC with a USB port for online mode
- HOPE5000 software for online mode

Note: Programming sockets are consumables, it is suggested to maintain and update them regularly.

#### Package Contents



Item	Content Name	Count
1	e-WriterPro2	1
2	USB 2.0 TYPE-A to Type-C 1.8M USB Cable	1
3	5V USB Power Adapter	1
4	ICP lines 2×6 Pin Connector (30cm)	1

### Hardware Installation

Connect the e-WriterPro2 to the PC USB port using the USB cable.

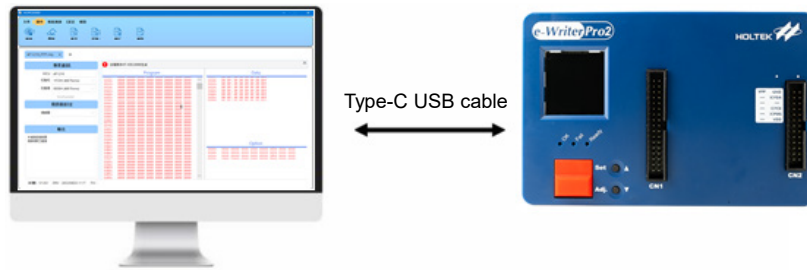

### Hardware Configuration

The name of each writer hardware section is shown in the following figure (e-WriterPro2). The following table explains each item.

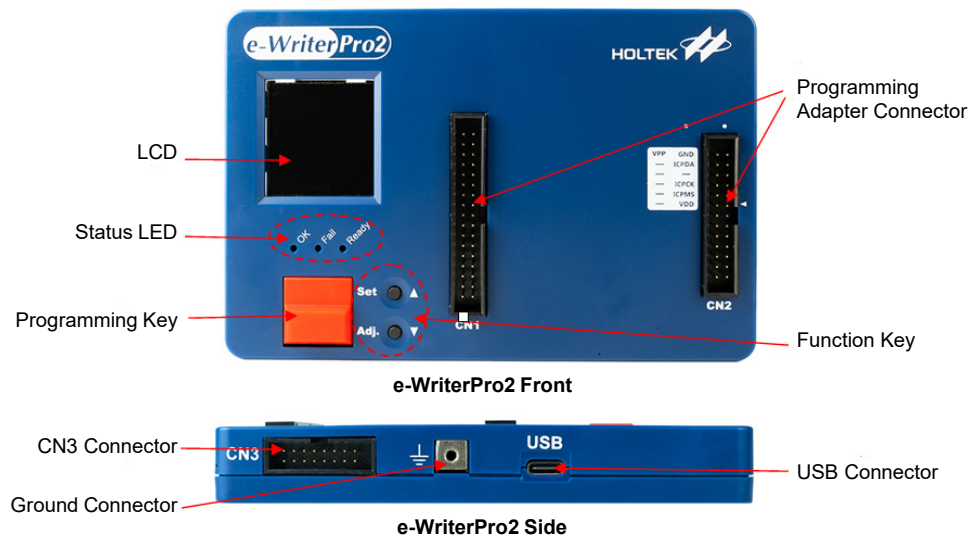

Item	Explanation
Programming Adapter Connector	Programming Pins
OK	Normal Status LED
Ready/Busy	Ready or Busy Status LED
Fail	Fail Status LED
Programming Key	Offline Mode Programming Key
USB Connector	Connect to PC via USB cable (online mode) or Connect to 5V power adapter (offline mode)
LCD	Displays information and to set the writer functions
Function Key	Switch LED pages and to set the writer functions
CN3 Connector	External control signal interface, refer to Appendix A
Ground Connector	Connector for ground wire

### LCD Display Introduction

The LCD display information has a total of 8 pages, including 6 pages of programming file information and 2 pages of setting information. Refer to the following description for details.

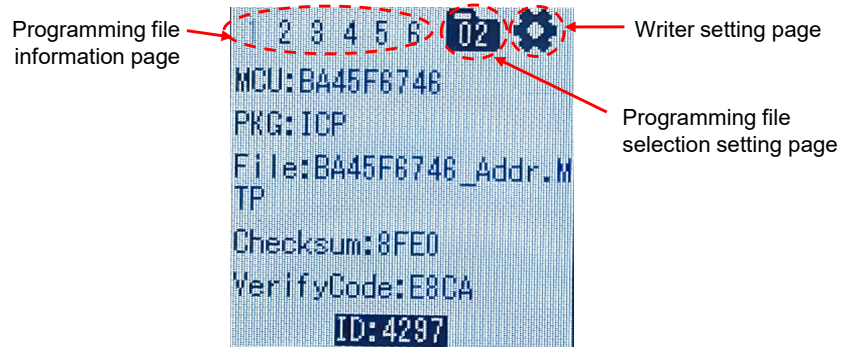

Display Page	Description
Programming file information page	Display the programming file information, including MCU type, package, file name and checksum etc.
Programming file selection setting page	Used to select the file to be programmed. The icon "02" indicates the current selected programming file number. Users can select the file by clicking the "Set" and "Adj." keys.
Writer setting page	Used to set the LCD brightness, the buzzer sound size and the display language selection.

### First Page

The display information is shown in the following figure.

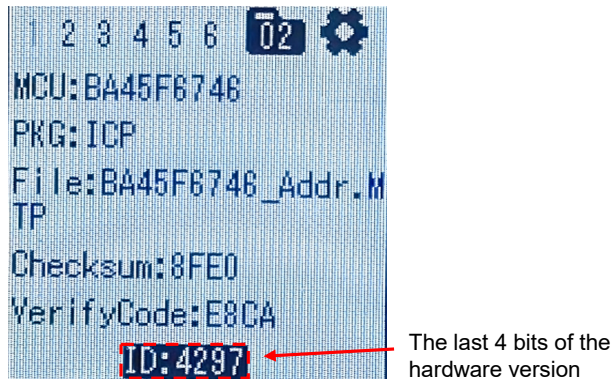

### Second Page

The display information is shown in the following figure.

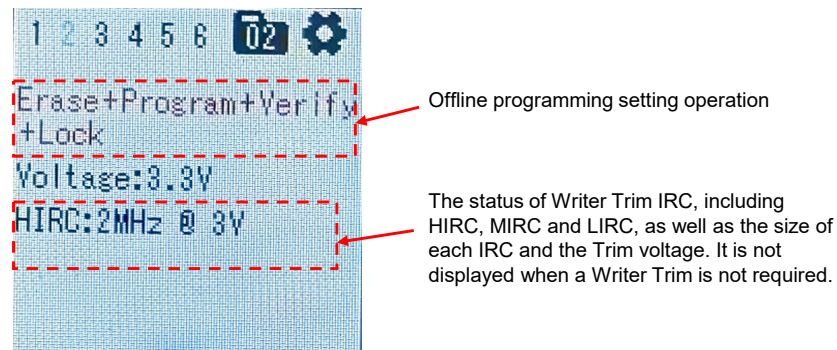

**Third Page**

The display information is shown in the following figure.

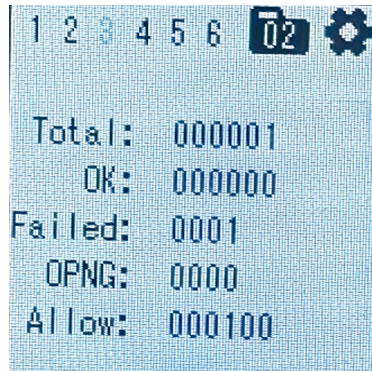

**Fourth Page**

The display information is shown in the following figure.

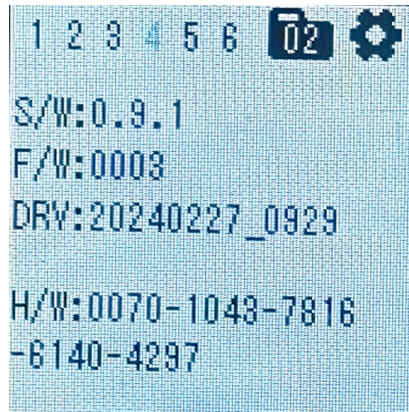

**Fifth Page**

The display information is shown in the following figure.

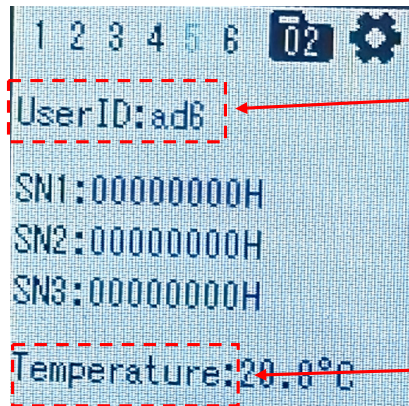

It is displayed only when the settings are set. If the settings are not set, the ID is blank.

It is displayed only when the Writer Trim temperature is required. If the Writer Trim temperature is not required, here is blank.

**Sixth Page**

The display information is shown in the following figure. This page is used to display the life and counter of the programming adapter.

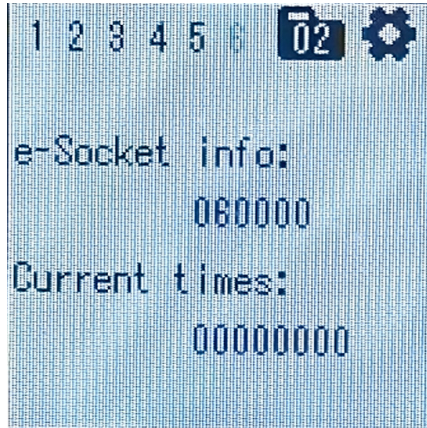

**Programming File Selection Setting Page**

The display information is shown in the following figure.

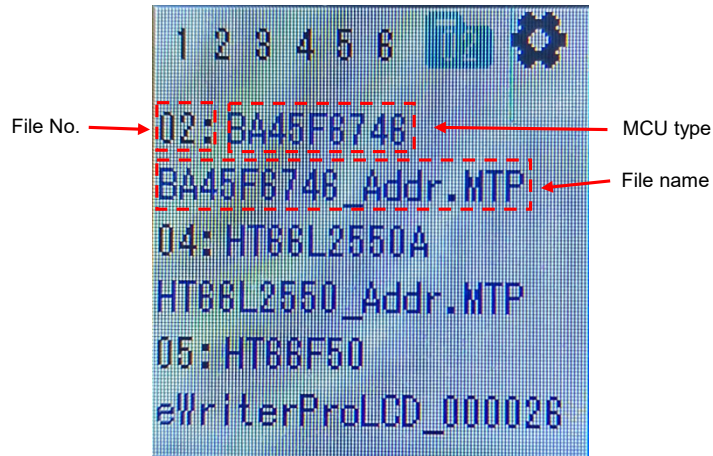

Click the button “Set” to enter the setting mode, then click the button “Adj.” and move down to select the programming file. Clicking the button “Adj.” moves to which programming file, the font color of the MCU type and file name of the programming file will be changed to Turkish blue. The files are selected in the order from 00 to 29. The specific setting is shown as follows.

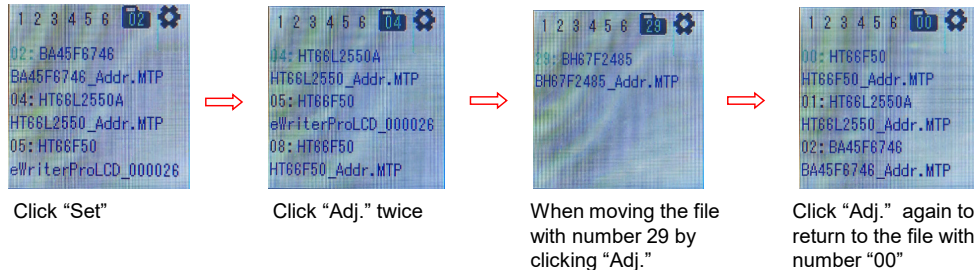

When clicking the “Adj.” key moves to the file to be selected, press the “Set” key to select the file. Switch to the first page on the LCD, and the information on pages 1 to 6 is changed to the information about the newly selected file.



**Writer Setting Page**

The display information is shown in the following figure.

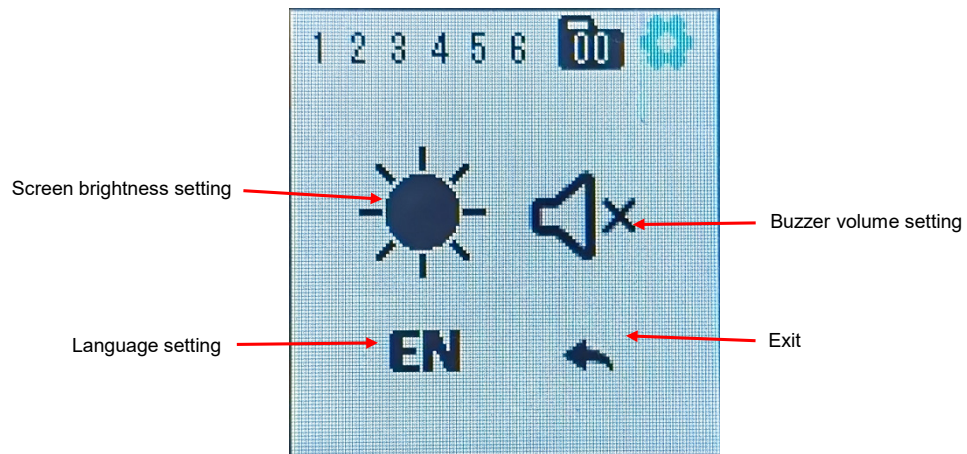

Press the “Set” key to enter the setting page. After the selection is completed, press the “Adj.” key to switch to the next item, as shown in the following table.

Item	Description	Note
Screen brightness setting	There are five levels, which can be selected by the “Set” key	
Buzzer volume setting	There are four levels, which can be selected by the “Set” key	
Language setting	There are three options, English, Simplified Chinese and Traditional Chinese, which can be selected by the “Set” key	
Exit	Press the “Set” key and the page returns to the first page	

## Chapter 8 Gang-Writer00-8 Introduce

The Gang-Writer00-8 main components are the G-ICPM00040 and G-ICPB00540. The G-ICPM00040 which is also known as the programming module, includes 4 programming units, namely ICP1~ICP4. This is used together with the G-ICPB00540 which is the Base Board. Together they can implement a powerful means of programming 8 Holtek 8-bit Flash MCUs in parallel to meet the high efficiency requirements for volume production.

### Main Features

- Supports Holtek 8-bit Flash MCU programming
- Uses the HOPE5000 software
- Programming files are downloaded to the programing module
- Supports programming module firmware online one-click quick update
- Compact size (166×75×23mm) for usage convenience with fixture
- Supports up to 8 sites parallel programming
- 2/4/6/8 sites parallel programming available
- Supports module extension to achieve up to 12/16 sites parallel programming
- Multiple programming status indicator interfaces (LED + LCM + BUZZER + Machine)
- Supports offline programming mode

### Hardware Introduction

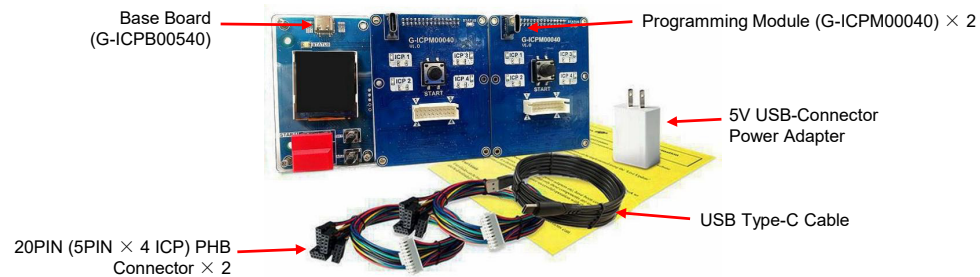

### Gang-Writer00-8 Monolithic Components

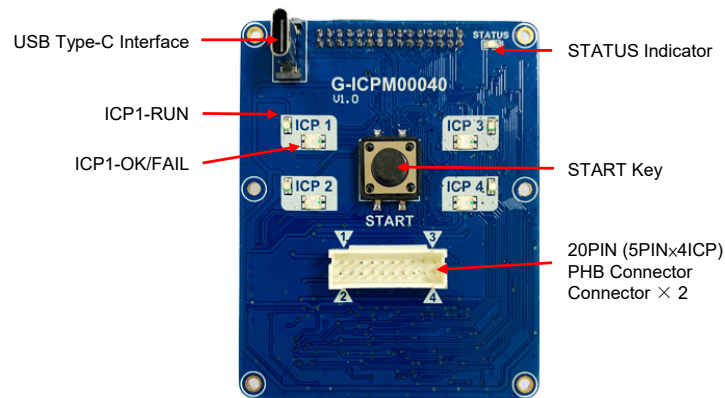

G-ICPM00040 – Programming Module

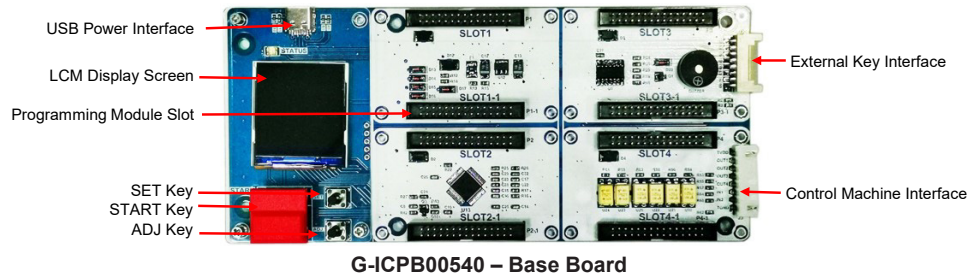

## Programming Module Independent Operation

### Online Programming Mode

In this mode, only the ICP1 unit works. Connect the programming module to a PC using a USB cable and open the software. The ICP1-RUN LED will be illuminated indicating that it is in the online programming mode, as shown in the following figure. For online programming specific operations together with the HOPE5000, refer to the corresponding descriptions below. Note that the online programming does not support the smart programming function.

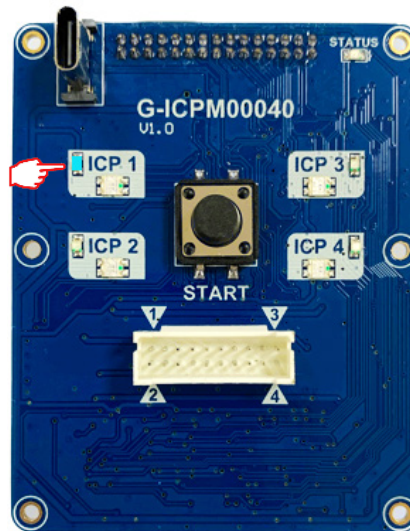

**Programming Module**

### Offline Programming Mode

#### Offline Programming Data Download

Connect the programming module to a PC via a USB cable. After the module has successfully connected, open the desired file and download it, as shown in the following Figure. Refer to the description below for the specific software operation procedures. When the offline data download has successfully completed, the STATUS LED will remain on.



Offline Programming Data Download – Single Module

**Offline Programming**

After a 5V/3A power is connected, the STATUS LED will remain on. At this time, the hardware will verify the offline data first, and the STATUS will flash once after the verification is completed (during the hardware verifies the offline data, the START key is disabled). After the offline data verification is completed, pressing the START key to implement programming. The programming states can be observed by the corresponding LEDs.

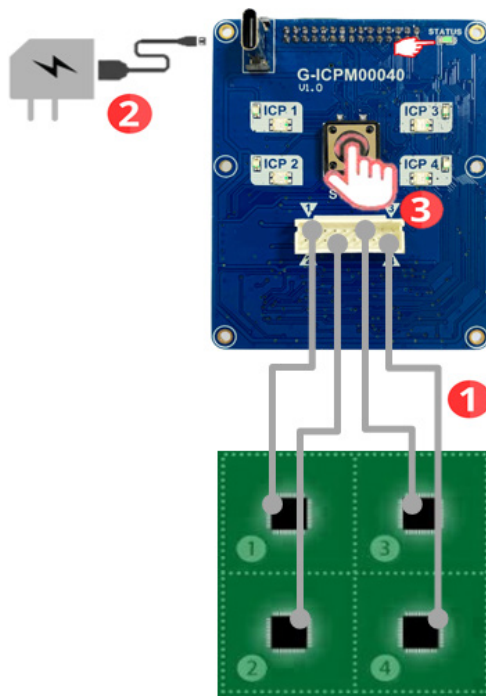

Offline Programming – Single Module

**Programming Mode Selection**

Either 2 or 4 site parallel programming can be selected using the OPTION S/W settings according to the actual requirements, as shown in the following Figure and Table. With regard to 6 or 8 site parallel programming description, refer to [Programming Mode Selection](#).

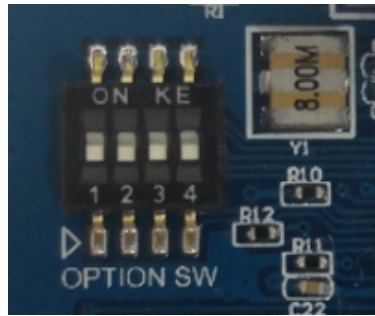

**OPTION S/W**

Switch1	Switch2	Site Settings
OFF	OFF	Enable the ICP1~ICP4 programming – factory default
ON	OFF	Enable the ICP1 and ICP2 programming
OFF	ON	Enable the ICP3 and ICP4 programming
ON	ON	Enable the ICP1 and ICP3 programming

**OPTION S/W Site Settings**

**Using the Programming Module together with the Base Board**

In the offline programming mode, using the programming module together with the base board can implement 2/4/6/8 sites parallel programming in the standard mode or 12/16 site parallel programming in the extension mode. To implement programming module offline data download, connect the programming module to the PC via a USB cable directly. It is not necessary to remove it from the base board. When the programming module is used together with the base board, the START key on the programming module is invalid.

**Base Board F/W Update**

The hardware connection is shown in the following figure. Using HOPE5000 to implement F/W update. Refer to [Chapter 2 Function Description – Setting](#) for details.

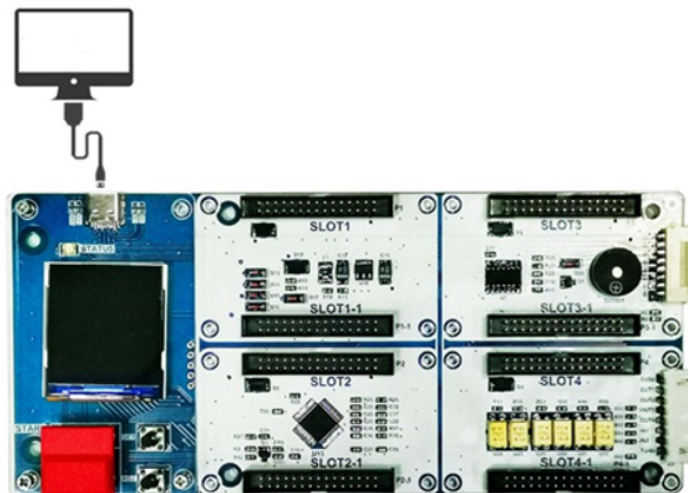

**Base Board Connected to the PC via a USB Cable**

### Offline Programming Mode

#### Offline Programming Data Download

The hardware connection is shown in the following figure and the specific operation steps are the same as [Offline Programming Mode – Offline Programming Data Download](#).

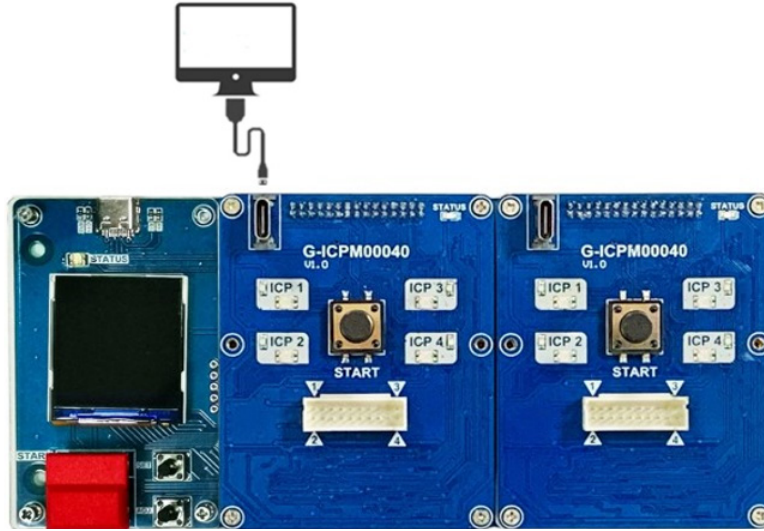

Offline Programming Data Download – Module & Base Board

#### Offline Programming

After the offline programming data has been downloaded successfully, remove the USB cable from the PC. Connect a 5V/3A power to the programming module after which then the STATUS indicator of each programming module will be on. At this time, the hardware will verify the offline data first, and the STATUS will flash once after the verification is completed (during the hardware verifies the offline data, the START key is disabled). After the offline data verification is completed, pressing the START key to start programming after which the programming results can be obtained by observing the LED indicator on the corresponding programming module.

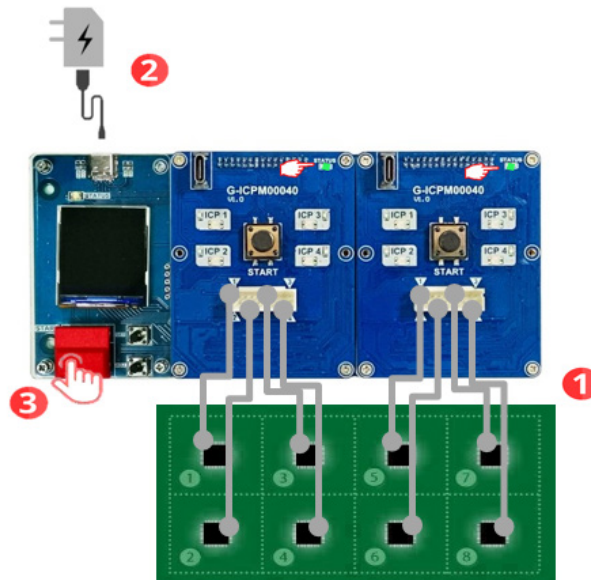

Offline Programming – Module & Base Board

### Programming Mode Selection

#### Standard Mode

2, 4, 6 or 8 site parallel programming can be selected by the OPTION S/W settings, as shown in the following figure.

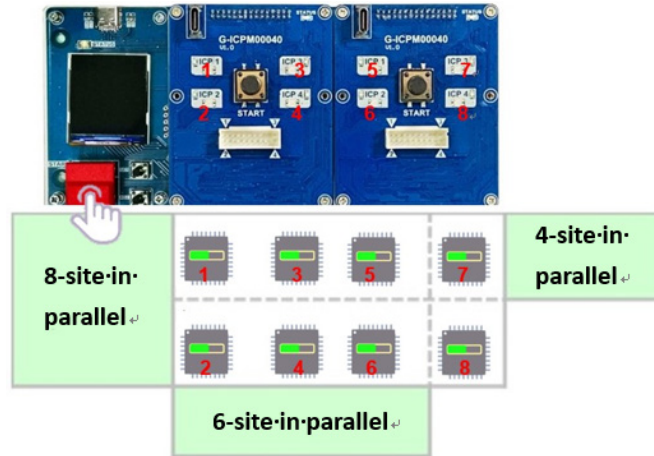

Programming Mode Selection – Standard Mode

#### Extension Mode

In offline programming mode, if the base board works together with 4 programming modules, up to 16 Holtek 8-bit Flash MCUs or 32-Bit MCUs can be programmed in parallel, as shown in the following figure.

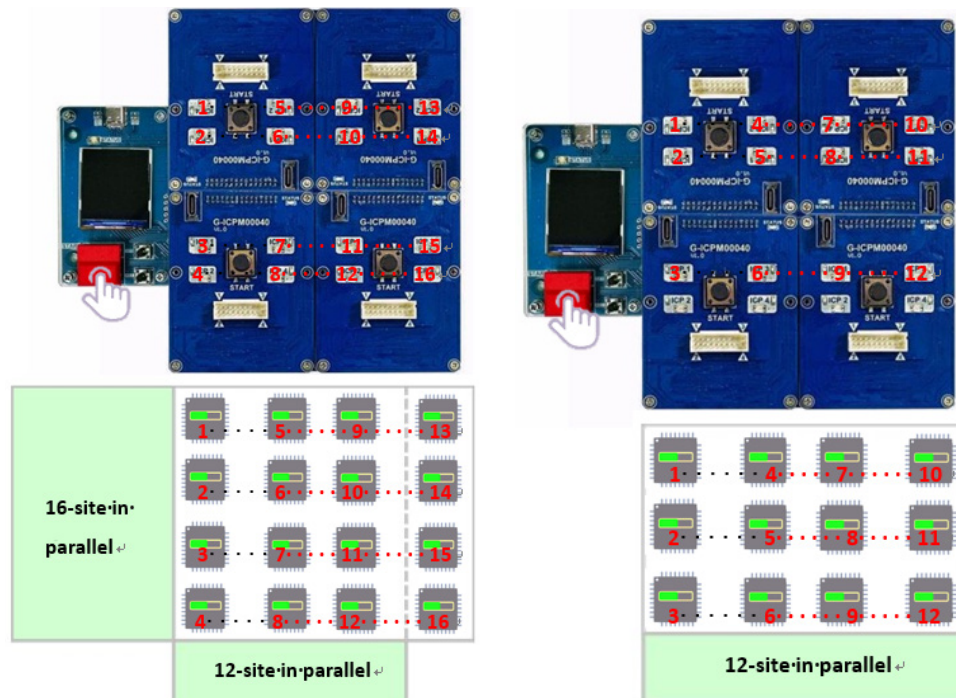

Programming Mode Selection – Extension Mode

### Base Board LCM Display Introduction

The LCM can display 5 pages of information, including 4 pages of programming file information and 1 page of setting page information, as shown in the following figure.

#### First Page

The display information is shown in the following figure.



#### Second Page

The display information is shown in the following figure.

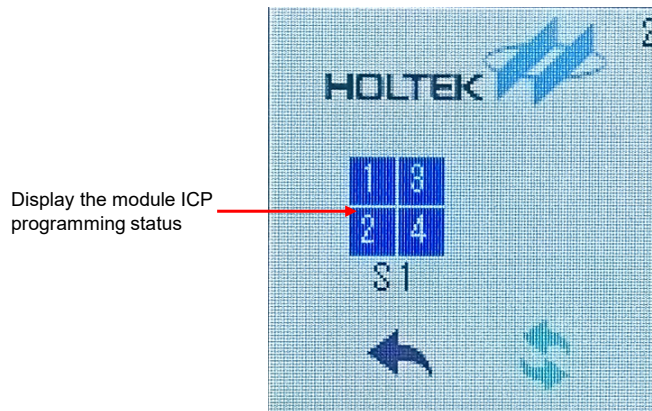

#### Third Page

The display information is shown in the following figure.



**Fourth Page**

The display information is shown in the following figure.

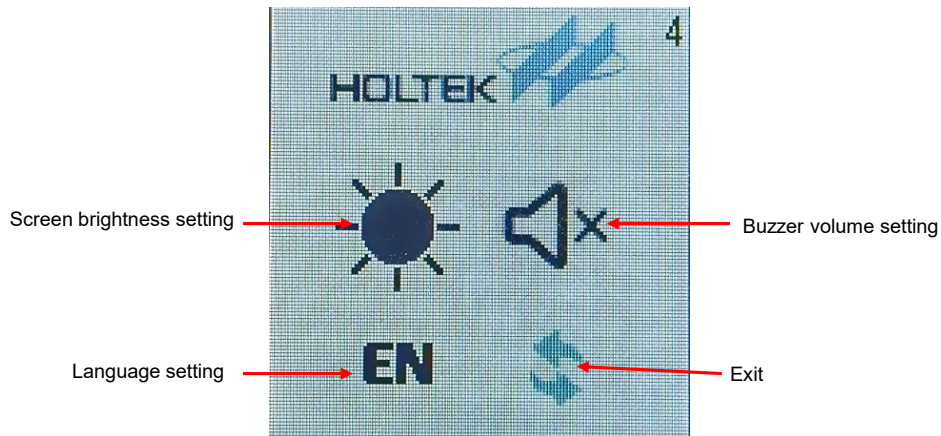

Press the “ADJ” key to enter the setting page and press the “ADJ” key to select. After the selection is finished, press the “SET” key to switch to the next item, as shown in the following table.

Item	Description	Note
Screen brightness setting	There are five levels, which can be selected by the “Set” key	
Buzzer volume setting	There are four levels, which can be selected by the “Set” key	
Language setting	There are three options, English, Simplified Chinese and Traditional Chinese, which can be selected by the “Set” key	
Exit	Press the “Set” key and the page returns to the first page	

**Fifth Page**

The display information is shown in the following figure.

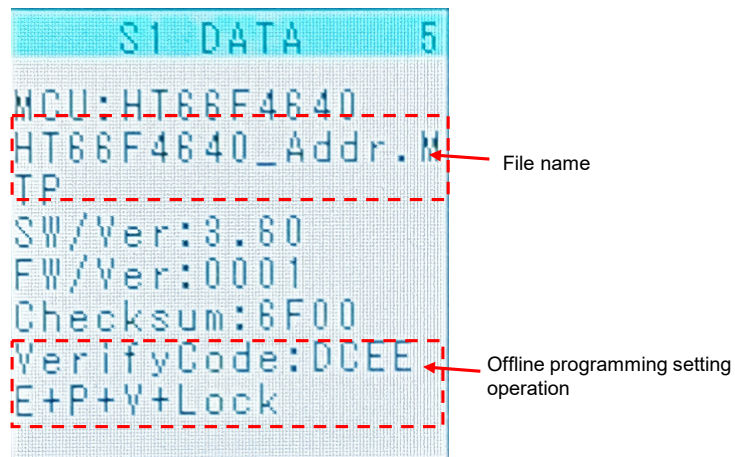

**Considerations**

- Regarding the power supply (5V/3A) and the programming lines, it is strongly recommended to use the original accessories included in the product.
- Each separate programming channel (ICPx) provides a current of only 150mA.
- The online programming mode does not support smart programming, namely auto programming. As shown in the following Figure, the auto programming button is disabled with a grey colour.

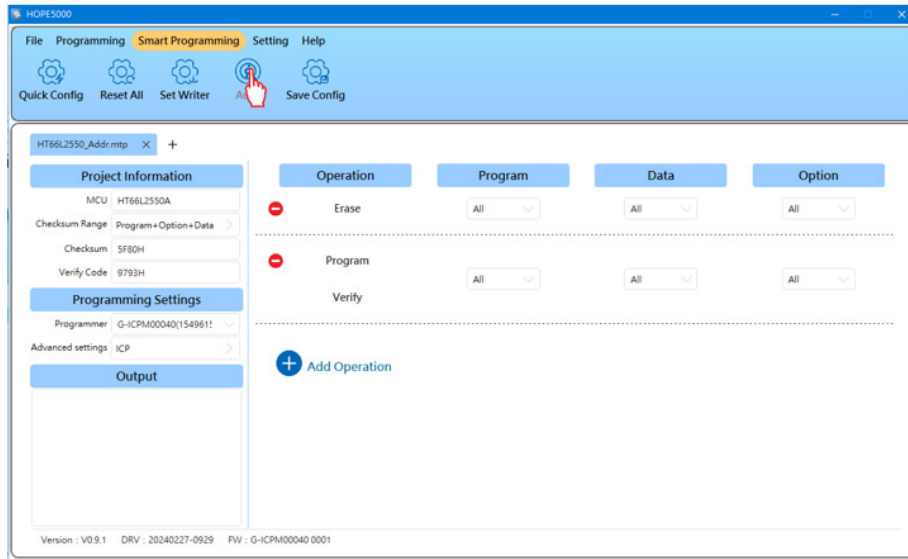

Smart Programming Mode Setting

## Chapter 9 Writer Usage

### Preparation before Programming

Before programming the MCU, use the development tools (HT-IDE3000) to generate an MCU programming file (.OTP/.MTP/.PND...etc). Then, connect the writer to the PC and execute the HOPE5000 software. Follow the steps below to execute MCU programming and complete the programming process.

### Case. 1 – Using External Digital Signals to Control e-WriterPro/e-WriterPro2 Programming

The following describes two methods of using external digital signals to control the e-WriterPro/e-WriterPro2 programming. These two methods are connecting a button to the e-WriterPro/e-WriterPro2 and using digital signal to control e-WriterPro/e-WriterPro2 programming”. These two methods are the same as pushing the red programming key on the e-WriterPro/e-WriterPro2, however the second method can also obtain the programming result.

#### Method 1 – Connect an external button

Connect a button to the Pin2/Pin4 of the e-WriterPro/e-WriterPro2 CN3 connector directly, as shown in the following figure.

Diagram:

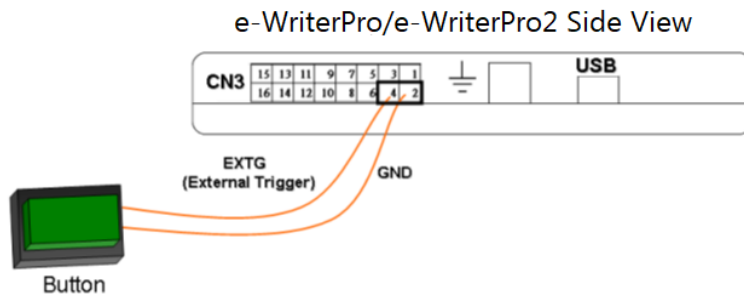

Picture

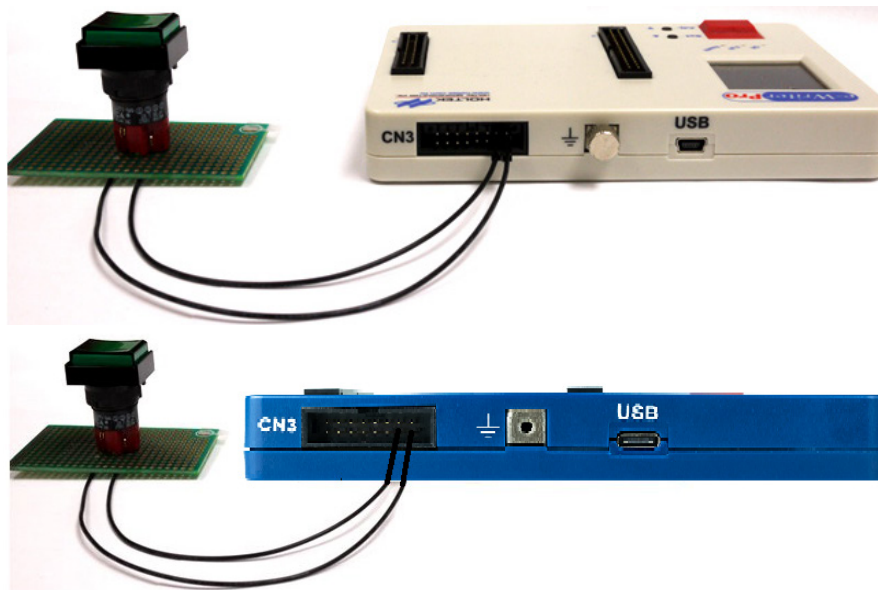

**Method 2 – Digital Signal Control**

The operation for using digital signals to control the e-WriterPro/e-WriterPro2 programming is: connect using the method as shown in the following figure and input the control signal timing.

**1. Hardware Connection Diagram**

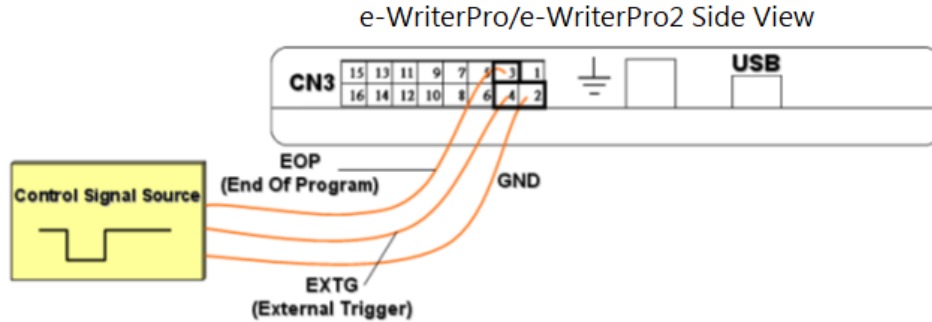

※ If the programming result is required, refer to Appendix A “e-WriterPro/e-WriterPro2 CN3 Pin Definitions” to connect to the corresponding BIN1~BIN7 pins. Then follow Step 4 of the following “Usage & Control Signal Timing” section to obtain the programming result.

**2. Usage & Control Signal Timing**

Control Signal Timing diagram

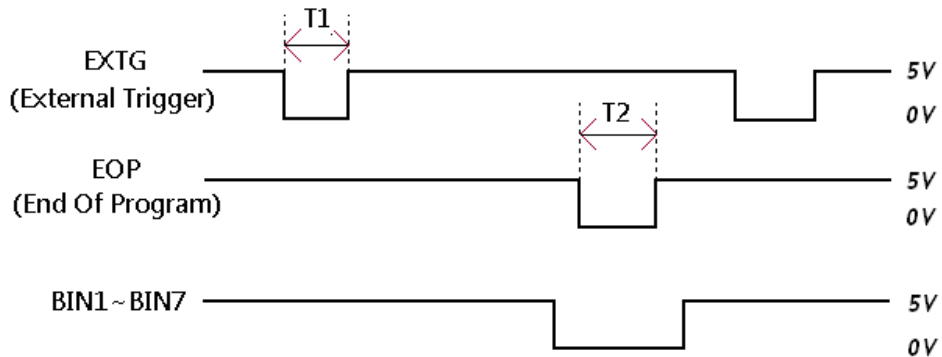

T1: e-WriterPro/e-WriterPro2 “External Trigger” low pulse,  $10\text{ms} < T1 < 500\text{ms}$

T2: e-WriterPro/e-WriterPro2 “End Of Program” low pulse,  $12\text{ms} < T2 < 100\text{ms}$

The usage is shown as follows:

- 1) Input a low pulse on the EXTG pin to start programming as shown by T1 in above figure. This operation is the same as pushing the red programming key on the e-WriterPro/e-WriterPro2.
- 2) Then the EOP pin can be polled continuously. If a low pulse is detected, as shown by T2 in above figure, this means that the programming is finished.
- 3) During the EOP low pulse as shown by T2 in above figure, check the status of BIN1~BIN7 to obtain the programming result. For example, if BIN1 is low during T2, this means Program OK. However if BIN4 is low during T2, this means Program Fail because the device is not blank.

Case. 2 – Using External Digital Signals to Control Gang-Writer00-8 Programming

External Key Interface

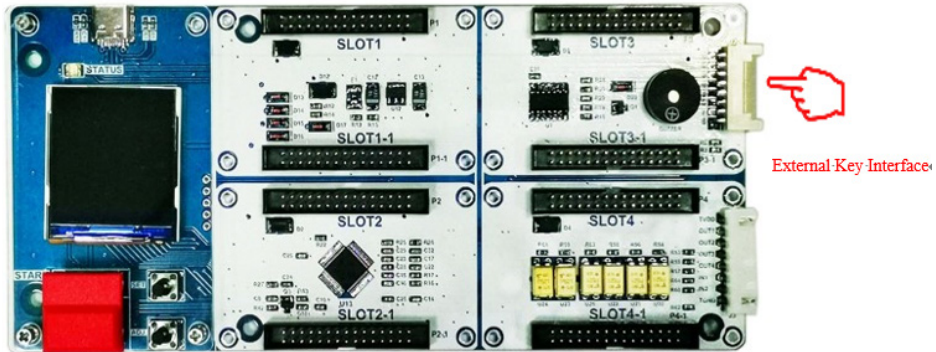

External Key Interface Explanatory Chart

PIN1: GND	PIN2: The external key can enable the SLOT1~SLOT4 programming at the same time.
PIN3: GND	PIN4: The external key can enable the SLOT1 and SLOT3 programming at the same time.
PIN5: GND	PIN6: The external key can enable the SLOT2 and SLOT4 programming at the same time.

Note: The PIN4 or PIN6 can be used to enable different SLOT programming modules and program different files at the same time.

External Key Interface Pins

Control Machine Interface

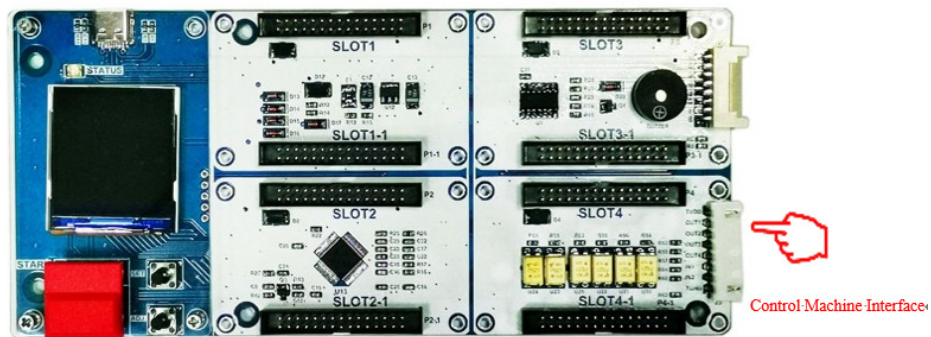

Control Machine Interface Explanatory Chart

Item	Pin	Functional Description	Signal Direction
1	TVDD	External VDD signal	←
2	OUT1	BUSY: Programming busy signal	→
3	OUT2	PASS: Programming successful signal	→
4	OUT3	FAIL: Programming failed signal	→
5	OUT4	NC	→
6	IN1	START: Programming trigger signal	←
7	IN2	NC	←
8	TGND	External GND signal	←

Note: The above interface pins are electrically isolated using opticalcoupler components. The TVDD ranges from 3.3V to 7V.

Control Machine Interface Pins

1. When the device is powered on and no executed programming, the START is high, and the BUSY, PASS, and FAIL are high.
2. The START pin sends a low level of  $T_{start}$  length to trigger the program,  $50ms \leq T_{start} \leq 80ms$ .
3. When the program is started, the BUSY pin changes to low.
4. When the BUSY pin is high, PASS or FAIL changes to low, the program process is end.
  - When the BUSY pin is set to high and PASS is set to low, the program is successful.
  - When the BUSY pin is set to high and FAIL is set to low, the program is failed.

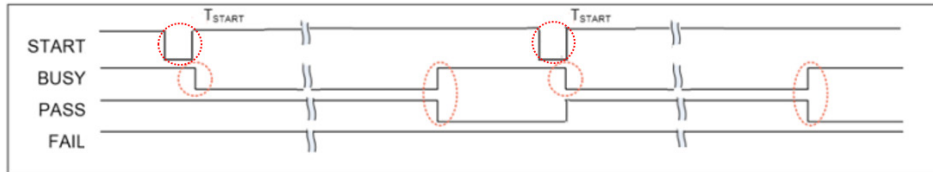

Successful Programming Waveform

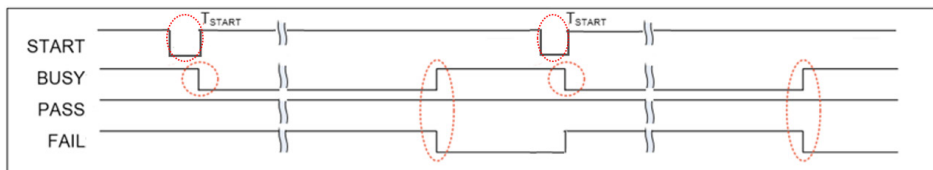

Failed Programming Waveform

### Case. 3 – Using the e-WriterPro In-circuit Programming Function

The following steps show how to use the e-WriterPro to implement in-circuit programming – ICP.

- Step 1

The Dupont thread is used to connect the target board with the connector CN1 on the e-WriterPro. For more information about the connection method, refer to the Appendix B “e-WriterPro ICP Pin Definitions and ICP Considerations”.

- Step 2

Execute the HOPE5000 and open the programming file (.OTP/.MTP/.PND). Then execute “Program”, “Erase”, “Check Blank”, “Verify” operations, etc.

- Step 3

Before downloading, the window as shown in the following figure will appear. Then the ICP(e-CON12A) or ICP(e-CON12C) package type should be selected.

Regarding the package selection, refer to the Appendix B – e-WriterPro ICP Pin Definitions and ICP Considerations. If the required package type is not shown, upgrade the HOPE5000 to the latest version.

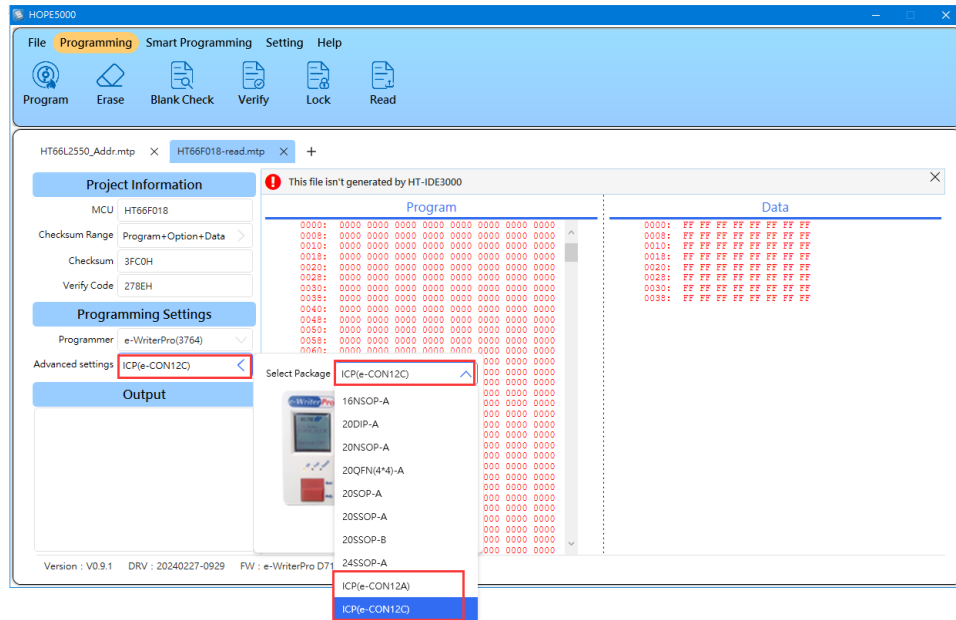

- Step 4  
After the download has finished, the “Erase”, “Program” and “Verify” operations, etc., can be executed.

## Case. 4 – Using the e-WriterPro2 In-circuit Programming Function

The following steps show how to use the e-WriterPro2 to implement in-circuit programming – ICP.

- Step 1  
Use the ICP cable as supplied with the e-WriterPro2 and [shown in Figure in the package contents of Chapter 7](#). It is used to connect the target board with the connector CN2 on the e-WriterPro2. For more information about the connection method, refer to the Appendix E “e-WriterPro2 ICP Pin Definitions and ICP Considerations”.
- Step 2  
Execute the HOPE5000 and open the programming file (.MTP/.OTP). Then execute “Program”, “Erase”, “Check Blank”, “Verify” operations, etc.
- Step 3  
Before downloading, the window as shown in the following figure will appear. Then the ICP package type should be selected.  
Regarding the package selection, refer to the Appendix E – e-WriterPro2 ICP Pin Definitions and ICP Considerations. If the required package type is not shown, upgrade the HOPE5000 to the latest version.

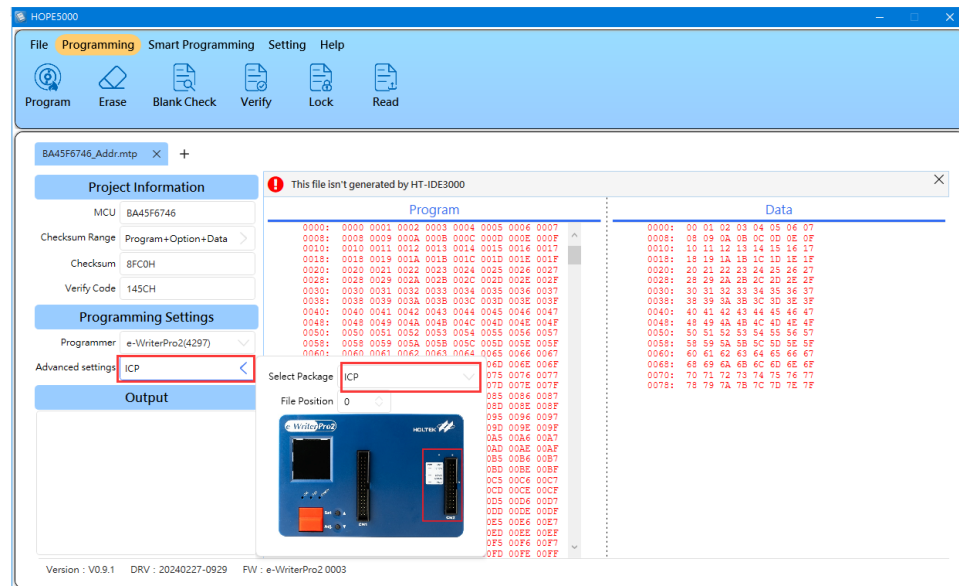

- Step 4

After the download has finished, the “Erase”, “Program” and “Verify” operations, etc., can be executed.

## Appendix

### Appendix A e-WriterPro/e-WriterPro2 CN3 Pin Definitions

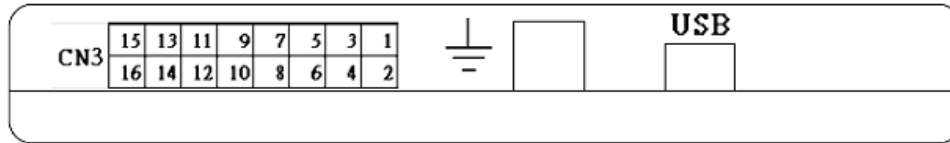

CN3			
Pin	Name	Definition	Direction
1	EXPWI/ USBPWO	External Power Input/ USB Power Output	—
2	GND	Ground	—
3	EOP	End Of Program	e-WriterPro/e-WriterPro2→
4	EXTG	External Trigger	e-WriterPro/e-WriterPro2←
5	BIN2	IC is locked	e-WriterPro/e-WriterPro2→
6	BIN1	Check ID/Blank Check/Program/Verify/Erase OK	e-WriterPro/e-WriterPro2→
7	BIN7	Lock IC failed	e-WriterPro/e-WriterPro2→
8	—	N/A	—
9	BIN4	IC is not blank	e-WriterPro/e-WriterPro2→
10	BIN3	Check ID failed (for OTP MCUs)/Erase failed (for Flash MCUs)	e-WriterPro/e-WriterPro2→
11	BIN6	Verify failed	e-WriterPro/e-WriterPro2→
12	BIN5	Program failed	e-WriterPro/e-WriterPro2→
13	—	N/A	—
14	SDA	I <sup>2</sup> C SDA (Reserved)	e-WriterPro/e-WriterPro2↔
15	—	N/A	—
16	SCL	I <sup>2</sup> C SCL (Reserved)	e-WriterPro/e-WriterPro2→

### Appendix B e-WriterPro ICP Pin Definitions and ICP Considerations

#### 1. e-WriterPro ICP Pin Definitions

The following table lists all kinds of ICP packages and the corresponding pin definitions. The following two steps introduce how to obtain the required pin definition.

Step 1. Obtain the ICP type for the MCU being used:

(Refer to the Holtek website: Home → Products → General Purpose 8-Bit MCU → Find the corresponding MCU according to the different categories of MCUs → Development Tools)

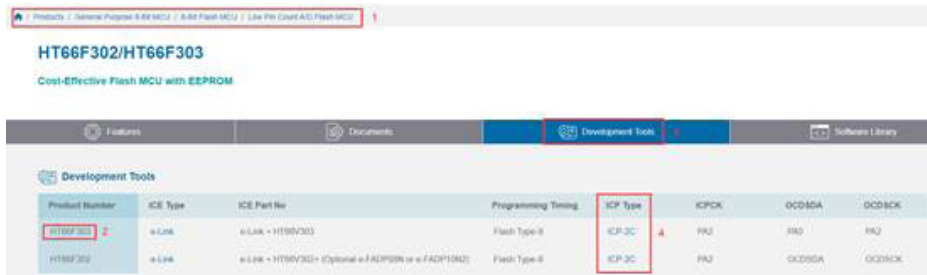

Step 2. Obtain the ICP package and pin definitions of each ICP type from this table.

ICP Type	ICP Package on HOPE5000	ICP Pin Definition Link
ICP-1A	ICP(e-CON12B)	<a href="#">ICP-1A</a>
ICP-1B	ICP(e-CON12B)	<a href="#">ICP-1B</a>
ICP-1C	ICP(e-CON12B)	<a href="#">ICP-1C</a>
ICP-1D	ICP(e-CON12B)	<a href="#">ICP-1D</a>
ICP-1E	ICP(e-CON12B)	<a href="#">ICP-1E</a>
ICP-1F	ICP (e-CON12B)	<a href="#">ICP-1F</a>
ICP-2A	ICP(e-CON12C)	<a href="#">ICP-2A</a>
ICP-2B	ICP(e-CON12C)	<a href="#">ICP-2B</a>
ICP-2C	ICP(e-CON12C)	<a href="#">ICP-2C</a>

1) ICP-1A

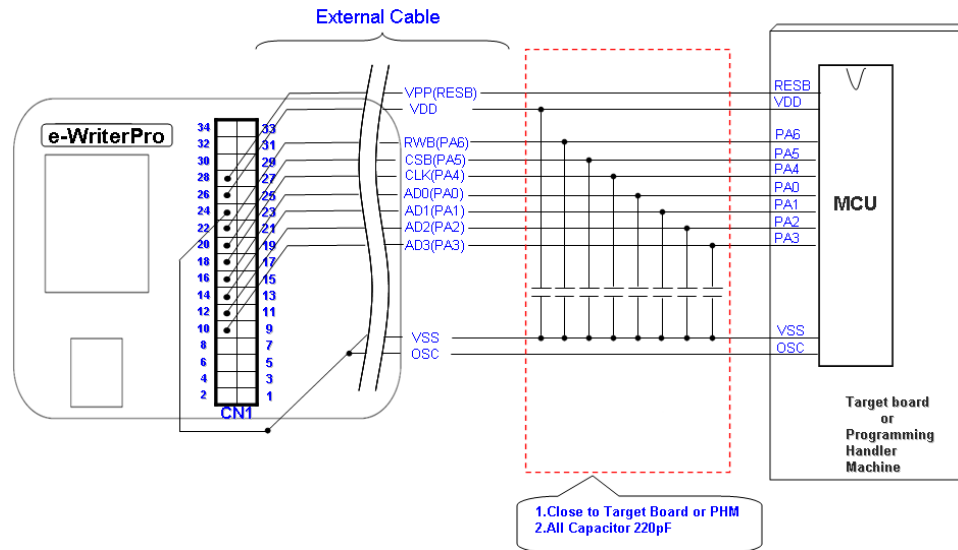

2) ICP-1B

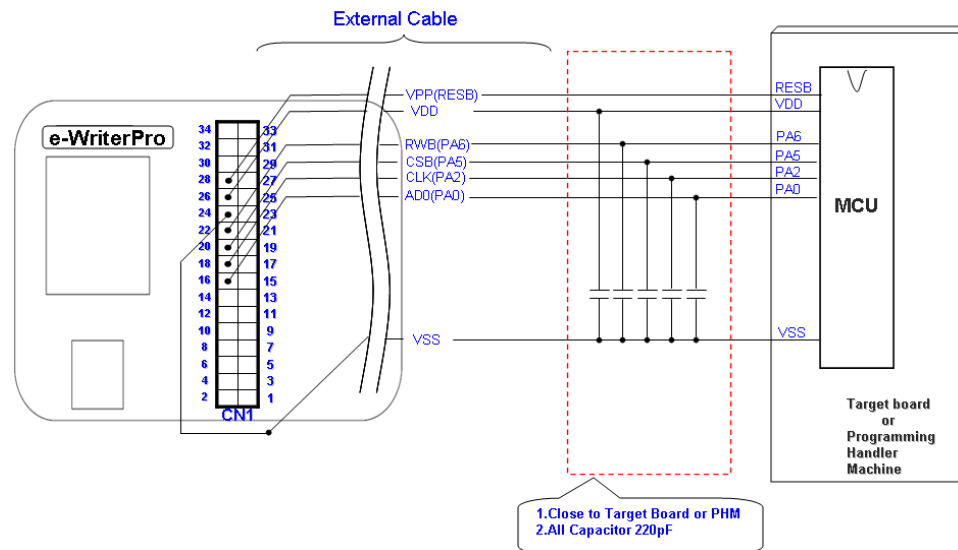

3) ICP-1C

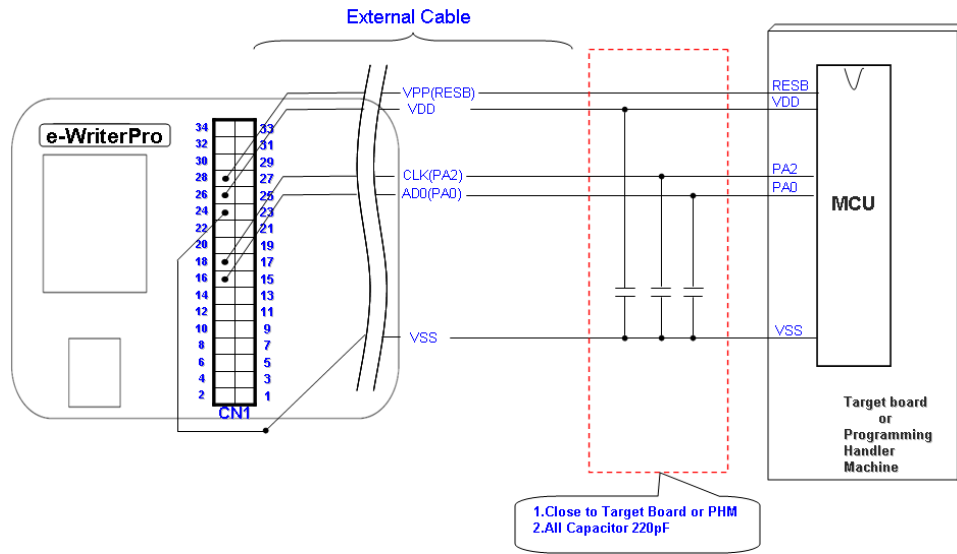

4) ICP-1D

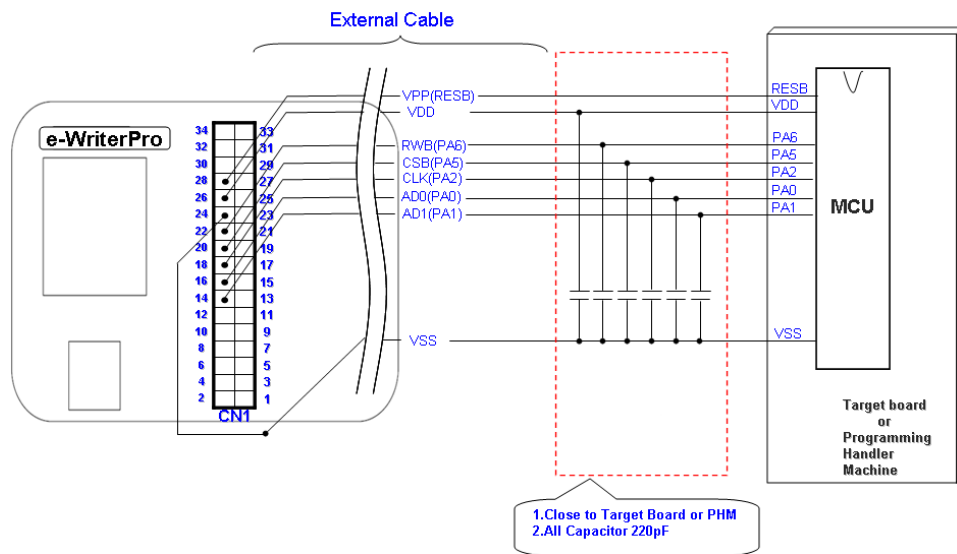

5) ICP-1E

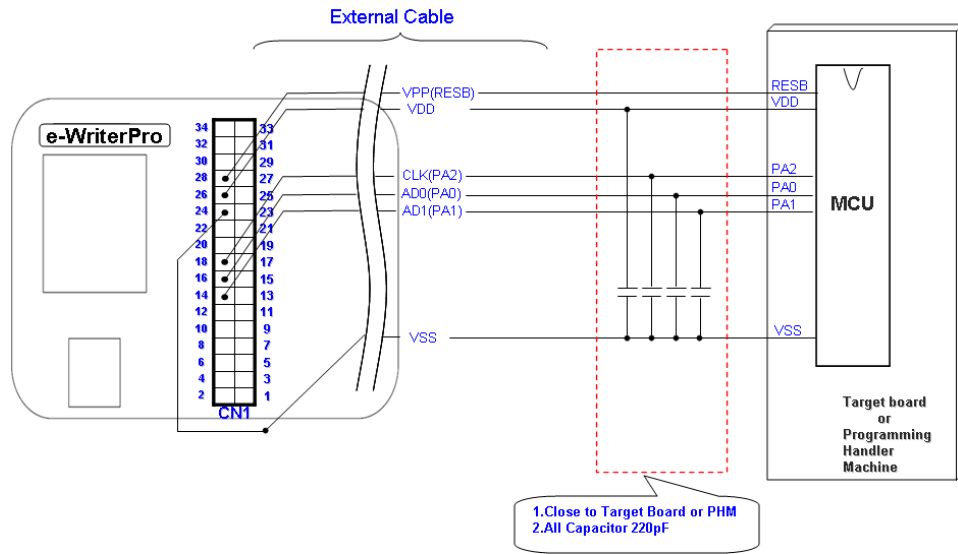

6) ICP-1F

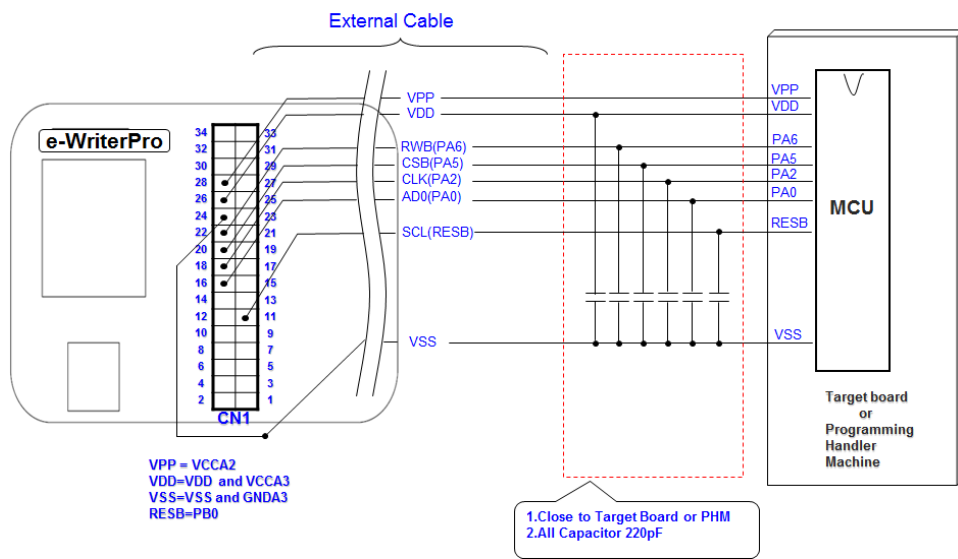

7) ICP-2A

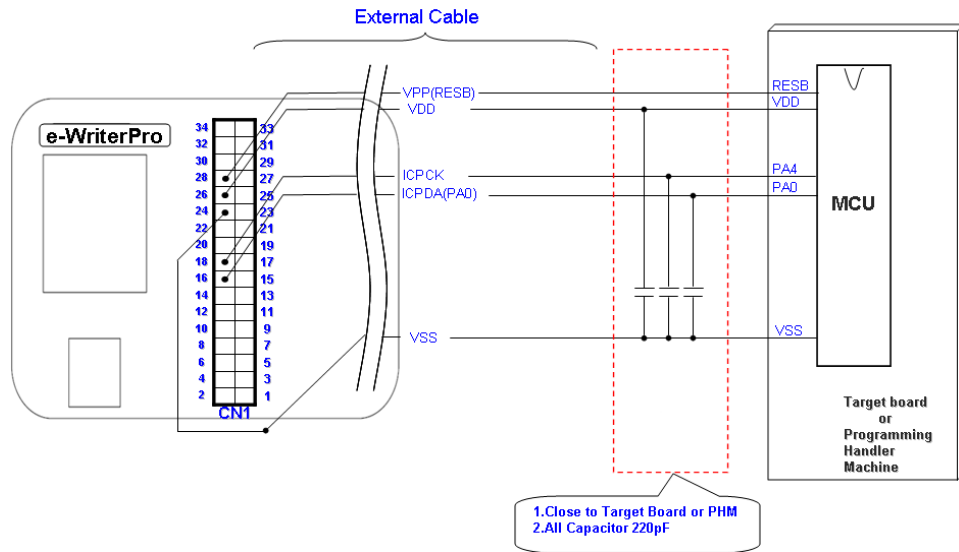

8) ICP-2B

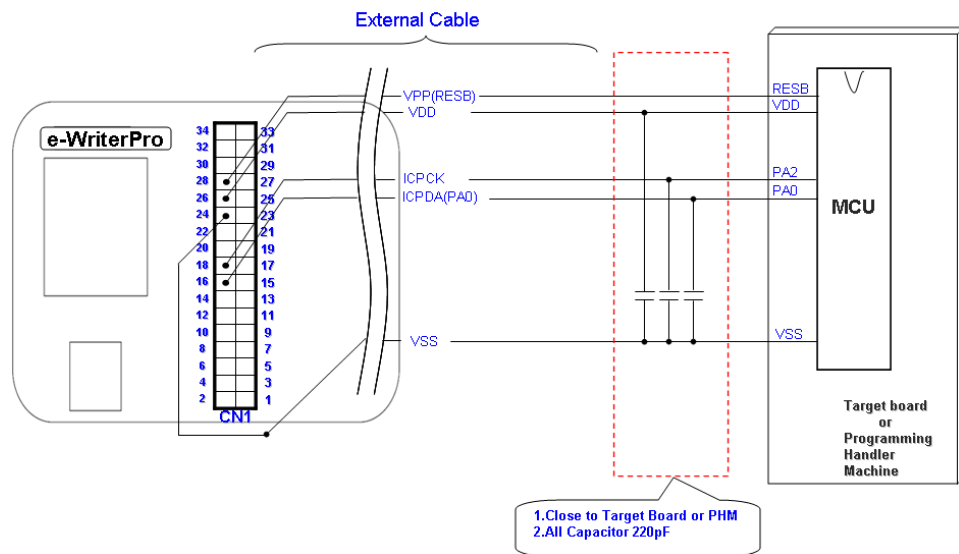

9) ICP-2C

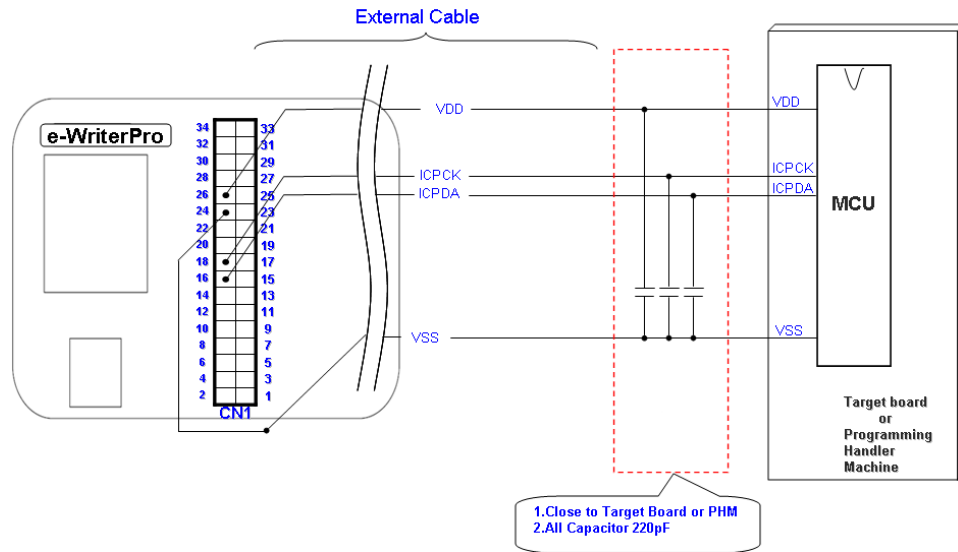

※ The actual pin location of the ICPDA and ICPCK pins in different MCUs may be different. Refer to the related chapter of the corresponding MCU datasheet.

2. e-WriterPro ICP Programming Considerations

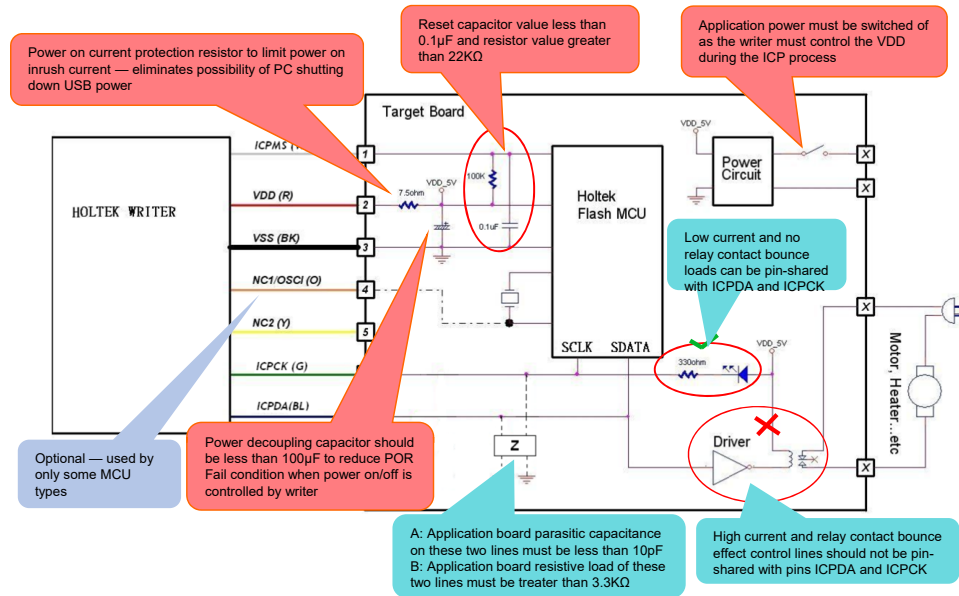

**Appendix C e-WriterPro/e-WriterPro2 LED Status Description**

The writer supplies three LEDs to represent the programming results by LED light status.

The status of each LED is:

ON: LED is turned on

OFF: LED is turned off

Fast Flash: LED flashes for each 0.2s

Middle Flash: LED flashes for each 0.5s

Slow Flash: LED flashes for each 0.8s

The following table lists the definitions of various flashing states of each LED light.

Blue LED (OK)	Yellow LED (Ready/Busy)	Red LED (Fail)	Description
<b>During Writer Power On</b>			
ON	ON	ON	Check the writer when the writer powers on.
OFF	OFF	Fast Flash	The writer is failure.
OFF	Slow Flash	OFF	The writer is OK.
<b>During Normal Operation</b>			
OFF	OFF	Fast Flash	The writer is failure.
Middle Flash	OFF	OFF	The programming operation is being executed (Busy).
Slow Flash	OFF	OFF	Operation is OK or the writer is standby.
OFF	OFF	Fast Flash	Operation has failed.

**Appendix D Writer Messages**

Most errors occurred on the writer result from the incorrect operation of the hardware. In the first instance take note of the following points:

- Check that the writer is properly connected – connect to the PC for the online mode or to a power adapter for the offline mode.
- Check that the programming adapter type is correct.
- Check that the IC is properly located in the programming adapter and the bar is pulled down and the IC type is correct.
- Try a different IC to check if the problem still occurs.
- For the problem still occurs, reboot the PC, power on the writer and try again.

The following are the writer error messages and their explanations:

- Chip ID is Mismatched
  - The IC type put on the writer is different from that in the opened file. Ensure that the IC put on the writer is correct.
- Chip is not Blank
  - The IC has been programmed.
- Program Error
  - Error occurred during programming.
- Verify Error
  - The data in the IC is different from the data in the writer.
- Lock IC Error
  - Error occurred when locking the IC.

- Read Error
  - Error occurred when reading the IC.
- Writer User Data Error
  - Examination of the programming data failed when the writer powers on. Download the programming data again.
- Smart Programming has not been set yet
  - No auto programming operations have been set therefore no offline programming is possible. Enter the Smart Programming Setting window to set auto programming operations.
- Erase Error
  - Error occurred when erasing the IC.
- Download to Writer Error
  - Error occurred when downloading the programming file from the PC to the writer.
- Upload to PC Error
  - Error occurred when uploading the programming file from the writer to the PC.
- Polling Code Data Exceeded
  - The polling code data has exceeded. Set the polling code data again.
- Program Error (Trim HIRC Fail)
  - The HIRC trim error occurred during programming. Check whether the programming pins ICPCK and ICPDA have connected a capacitor larger than 220pF or a large load component and check whether the VDD power (5V or 3V) is stable.
- Writer Flash Timeout
  - The writer flash does not respond during downloading. Download the data again. If the problem occurs again, contact an agent for further help.
- Writer F/W is too old
  - The F/W version of the writer is too old to use with this version of the HOPE5000. Contact with an agent to update the F/W.
- Chip is Locked
  - The IC is locked. No programming operation can be executed except for “Erase”.
- Test Flash Error
  - A writer hardware error occurred during downloading. Download the data again. If the problem occurs again, contact an agent for further help.
- The address in the IC where the user specified data to be written is not empty
  - Check if the IC is empty or if the user specified data setting is correct.
- Enter Programming Mode Error
  - Error occurred when entering the programming mode. Check if the IC is correct.
- Data Checksum Error
  - Data check error occurred when uploading or downloading. Download the data again.
- Writer System Data Error
  - Examination of the system data failed when the writer powers on. Download the programming data again.

- Hardware (Flash) Error
  - Examination of the writer hardware failed when powers on. Contact an agent or Holtek for further help.
- Hardware (Power) Error
  - Hardware error occurred during programming. Check if the IC and the programming adapter are correct and properly placed. If the problem occurs again, contact an agent or Holtek for further help.
- Power Error! Please Re-power on the Writer
  - Error occurred on the writer power. Power on the writer and try again.
- Timeout
  - Writer has timed out, power on the writer again.
- Writer is Busy
  - Writer is busy, power on the writer again.

**Appendix E e-WriterPro2 ICP Pin Definitions**

e-WriterPro2 ICP pin definitions:

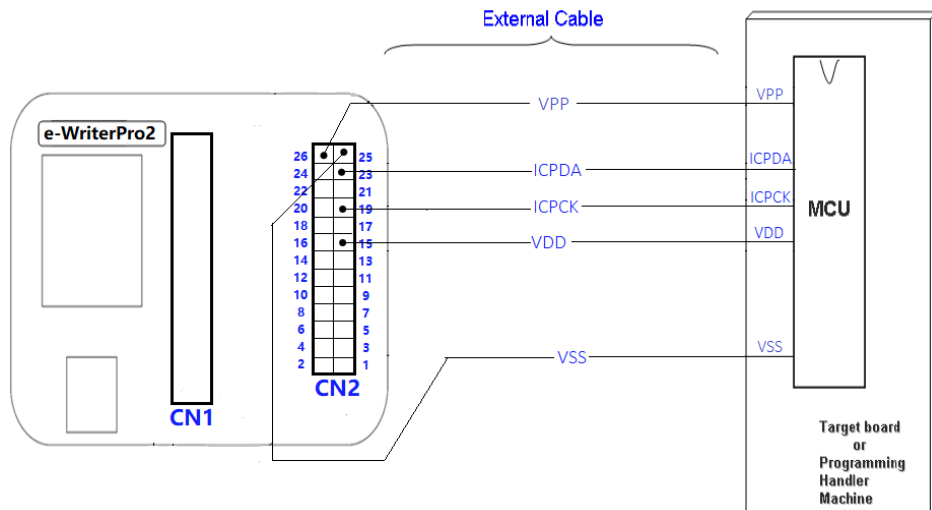

Appendix F Gang-Writer00-8 LED Status Description

LED Indicator	Power On Status	Programming Process Status	Programming Complete Status
<b>Online Programming</b>			
STATUS	On	Off	On (programming successful) Off (programming failed)
ICP1-RUN	On (ICP1 connection is successful) Off (ICP1 connection has failed)	Flash (mode1)	On
ICP1-OK/FAIL	Off	Off	Off (programming successful) FAIL LED flash (mode4: Programming failed)
<b>Offline Programming</b>			
STATUS	On (the programming operation can be implemented after flashing once)	Off	On (programming successful)
	Flash (mode2) (offline programming data error)		Off (programming failed)
	Flash (mode3) (power error)		
ICPx-RUN x=1, 2, 3, 4	Off	Flash (mode1)	Off
ICPx-OK/FAIL x=1, 2, 3, 4	Off	Off	OK LED will remain on 3s (programming successful) FAIL LED flash (mode3: Power error) (mode4: Programming failed)

LED Status Definition

Note: The STATUS indicator is off during the offline programming download process and is on after the download has completed successfully.

LED Flash Status Definition:

Mode1:



Mode2:



Mode3:



Mode4:



LED Flash Status Definition

Appendix G Gang-Writer00-8 Module Board Interface Pin Introduce

20PIN (5PIN × 4ICP) PHB Connector



20PIN (5PIN × 4 ICP) PHB Connector

VDD1	ICPDA1	ICPCK1	RST1	GND1	GND3	RST3	ICPCK3	ICPDA3	VDD3
VDD2	ICPDA2	ICPCK2	RST2	GND2	GND4	RST4	ICPCK4	ICPDA4	VDD4

20PIN PHB Connector (8-Bit Flash MCU Program)

VDD1	SWDIO1	SWCLK1	RST1	GND1	GND3	RST3	SWCLK3	SWDIO3	VDD3
VDD2	SWDIO2	SWCLK2	RST2	GND2	GND4	RST4	SWCLK4	SWDIO4	VDD4

20PIN PHB Connector (32-Bit MCU Program)

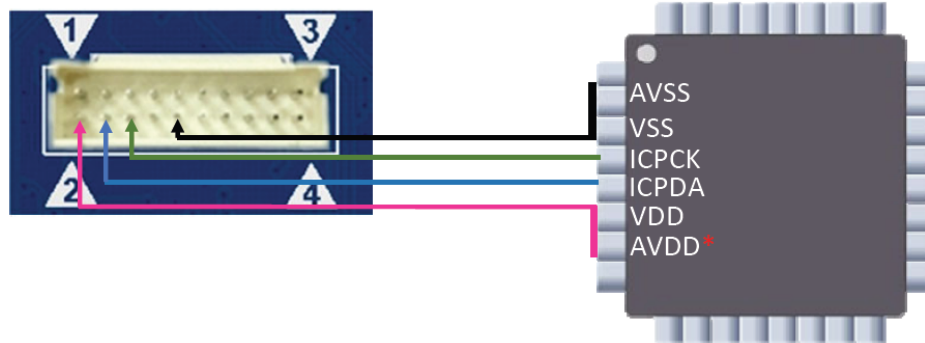

\* Note: It must be connected to the VDD or other power supply according to application requirements.

20PIN (5PIN × 4ICP) PHB Connector & Holtek MCU ICP Connection

Copyright© 2024 by HOLTEK SEMICONDUCTOR INC. All Rights Reserved.

The information provided in this document has been produced with reasonable care and attention before publication, however, HOLTEK does not guarantee that the information is completely accurate. The information contained in this publication is provided for reference only and may be superseded by updates. HOLTEK disclaims any expressed, implied or statutory warranties, including but not limited to suitability for commercialization, satisfactory quality, specifications, characteristics, functions, fitness for a particular purpose, and non-infringement of any third-party's rights. HOLTEK disclaims all liability arising from the information and its application. In addition, HOLTEK does not recommend the use of HOLTEK's products where there is a risk of personal hazard due to malfunction or other reasons. HOLTEK hereby declares that it does not authorize the use of these products in life-saving, life-sustaining or safety critical components. Any use of HOLTEK's products in life-saving/sustaining or safety applications is entirely at the buyer's risk, and the buyer agrees to defend, indemnify and hold HOLTEK harmless from any damages, claims, suits, or expenses resulting from such use. The information provided in this document, including but not limited to the content, data, examples, materials, graphs, and trademarks, is the intellectual property of HOLTEK (and its licensors, where applicable) and is protected by copyright law and other intellectual property laws. No license, express or implied, to any intellectual property right, is granted by HOLTEK herein. HOLTEK reserves the right to revise the information described in the document at any time without prior notice. For the latest information, please contact us.