



# Security & Safety Flash MCU Series Introduction



[www.holtek.com](http://www.holtek.com)

**HOLTEK SEMICONDUCTOR INC.**

# Introduction

Holtek's Security & Safety series product lineup includes fire protection/smoke detection and CO/GAS/PIR environmental detection dedicated MCUs.

The dedicated devices effectively integrate the external circuits according to the sensor function of each product, providing dedicated MCUs with high reliability and high integration that reduce peripheral components and improve production efficiency and consistency.



**The Holtek Security & Safety series of MCUs are all provided with professional technical consultation by the solution company "Anchip",** including providing technical support, market trends, competitive solutions and solving various problems in production for customers.

# Fire Protection/Smoke Detection Series

## Introduction

The smoke detection series of MCUs are suitable for various smoke detector products. The smoke detectors can be divided into stand-alone, wired networking and wireless networking. The operating principle of the smoke detectors is to detect smoke in the early stage of a fire using optical methods. When smoke enters the maze chamber, the smoke particles will cause the infrared beam to scatter, which will result in the IR receiver sensing some light emissions. The stronger the received light emissions, the higher the smoke concentration. When the smoke concentration reaches a preset threshold, an alarm signal will be triggered by sound, voice or linkage with other fire protection device to implement the fire warning function (Figure 1).

The networking smoke detection/fire protection products use dual-line bus communication technology. In the so-called dual-line bus communication (Figure 2), the master gives a command to the slave using a voltage signal modulation method while the slave responds to the master using a current modulation method. In this way a complete power supply and communication system between a master and slave only requires two lines.

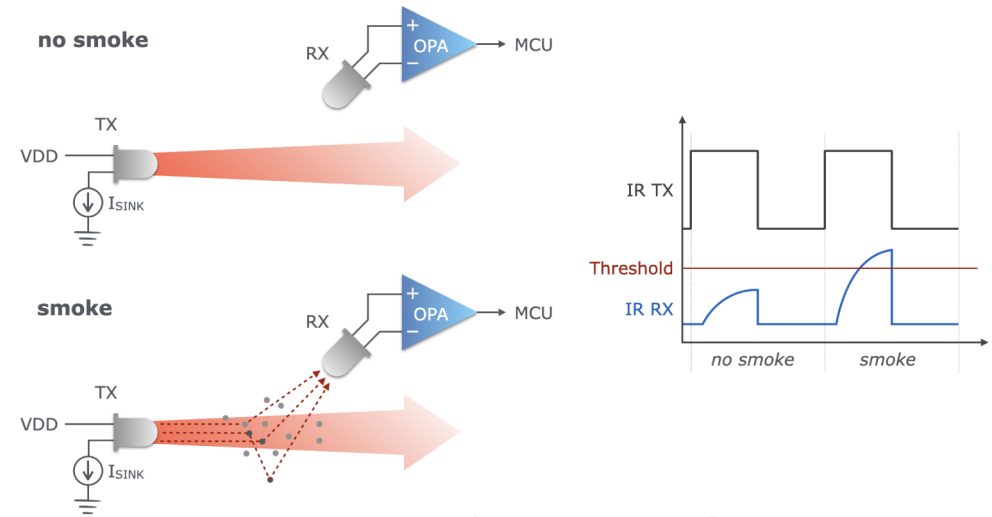

Figure 1. Smoke Detection Principle

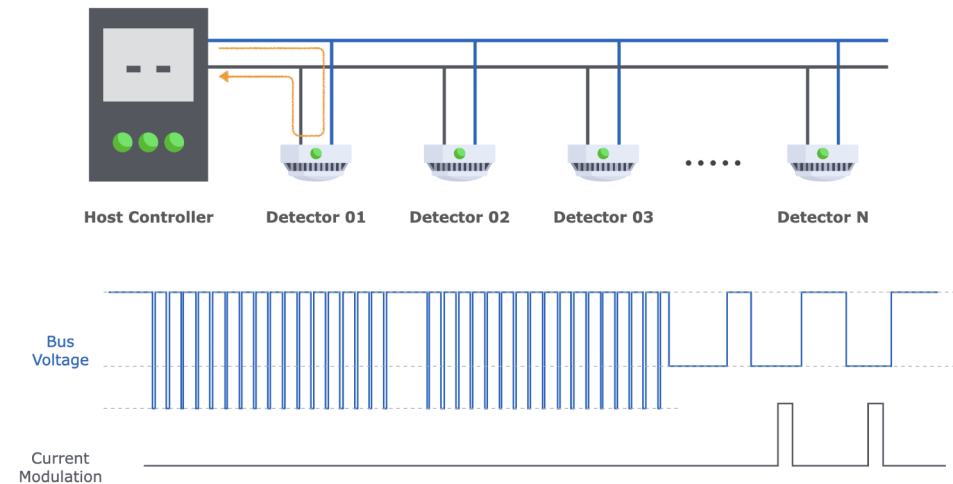

Figure 2. Dual-line Bus Communication Technology

The fire protection series is suitable for networking fire protection products other than smoke detectors. Holtek provides smoke detection dedicated MCUs and fire protection dedicated MCUs according to the product function type (Figure 3) to facilitate customer product development.

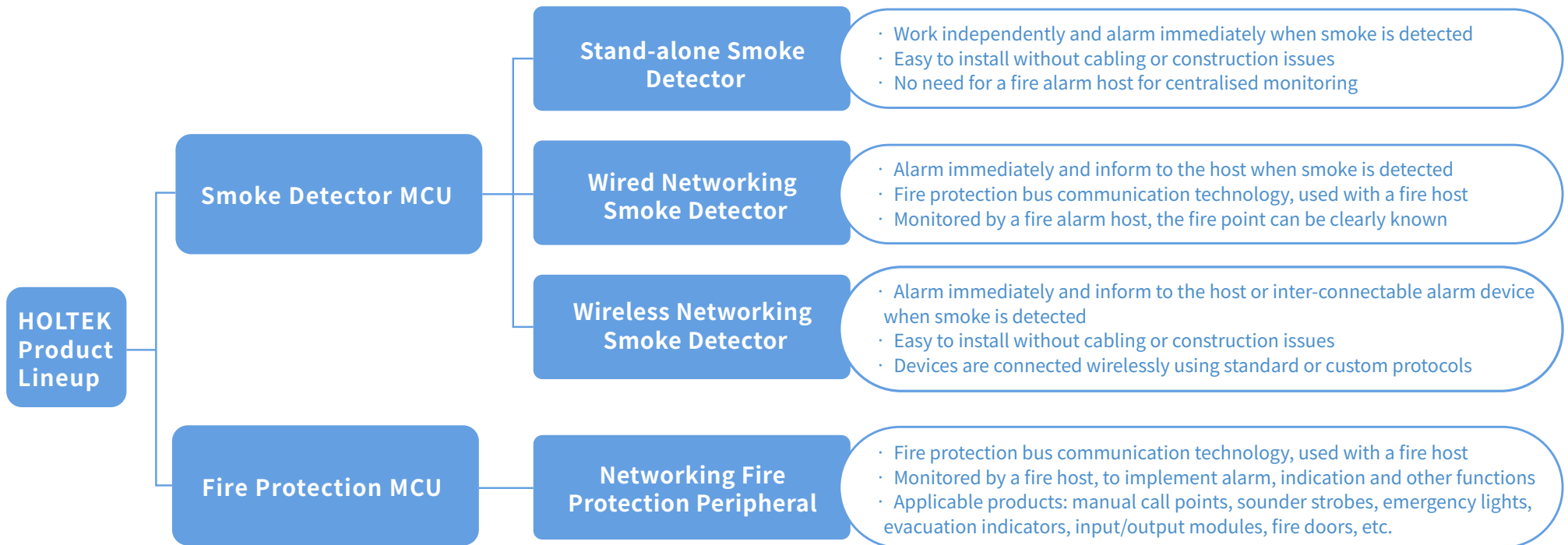

Figure 3. Holtek Fire Protection/Smoke Detection Product Lineup

## Product Series

All series of low power and high reliability dedicated smoke detection MCUs include an integrated smoke detection AFE circuit, which can reduce peripheral components and improve production efficiency and consistency. They also have two constant current drivers, which can drive IR, red or blue LEDs to meet dual-wavelength detection requirements.

The 8-bit smoke detection dedicated MCU series is divided into general purpose type, boost type, buck type, event recording type, wired networking type with integrated dual-line bus communication and wireless networking type. Customers can preliminarily select the desired MCU according to their product functional requirements (Figure 4).

The fire peripheral dedicated MCU series includes an integrated dual-line bus communication (also known as Power Line Transceiver) function, which is suitable for wired networking fire protection interface devices.

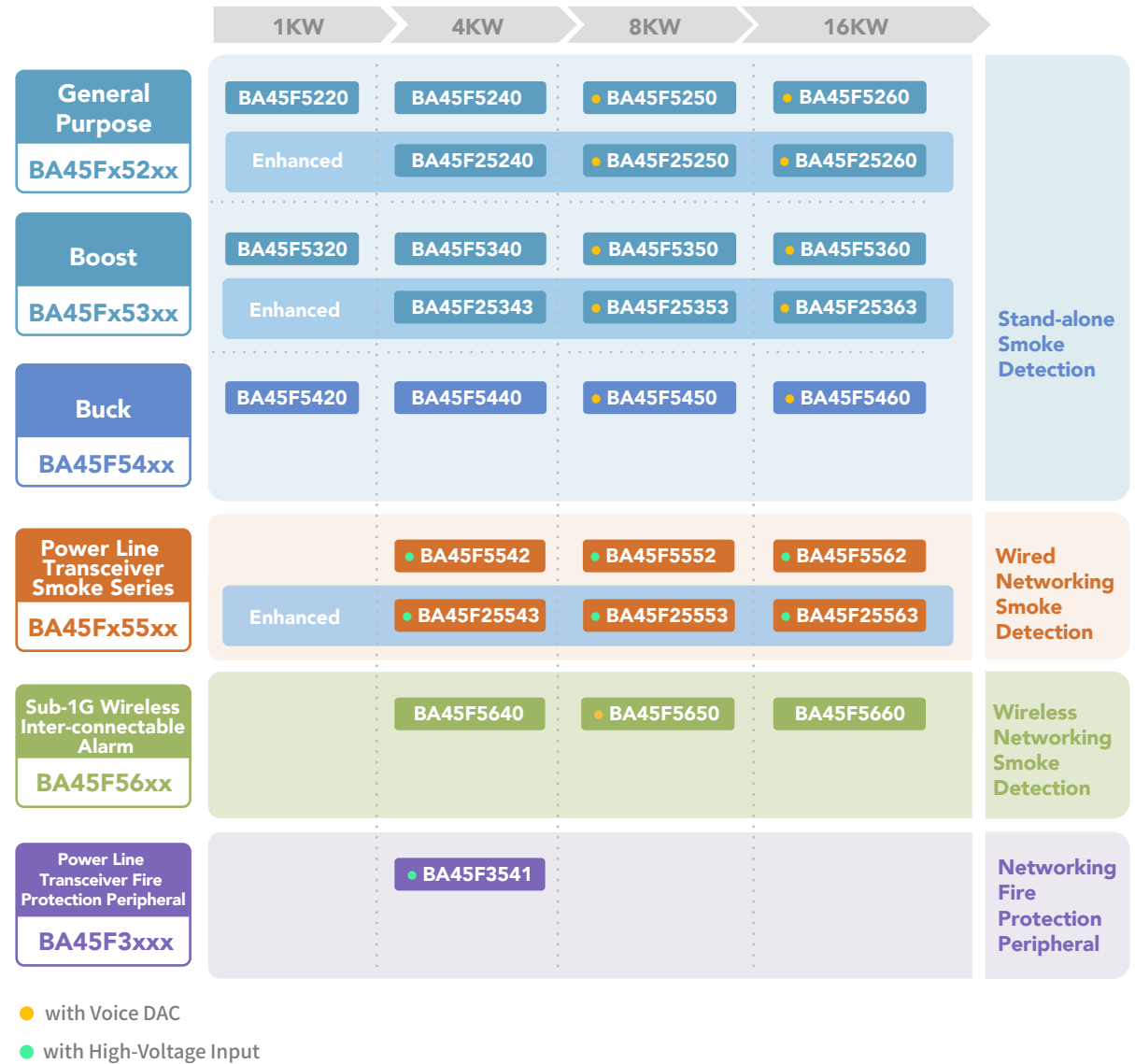

Figure 4. Fire Protection/Smoke Detection 8-Bit MCU Series Selection Guide

## Smoke Detection Series

### Product Features

- Dual-channel digital adjustable constant current transmitter driver circuit, improving the identification of black and white smoke in fire scenes (Figure 5)
- Integrated signal conversion analog front end (AFE) circuit

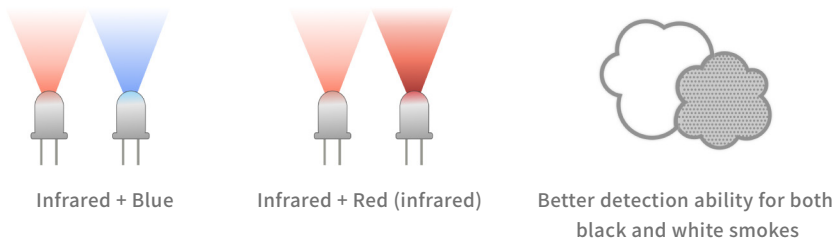

Figure 5. Dual-channel Adjustable Constant Current Emission

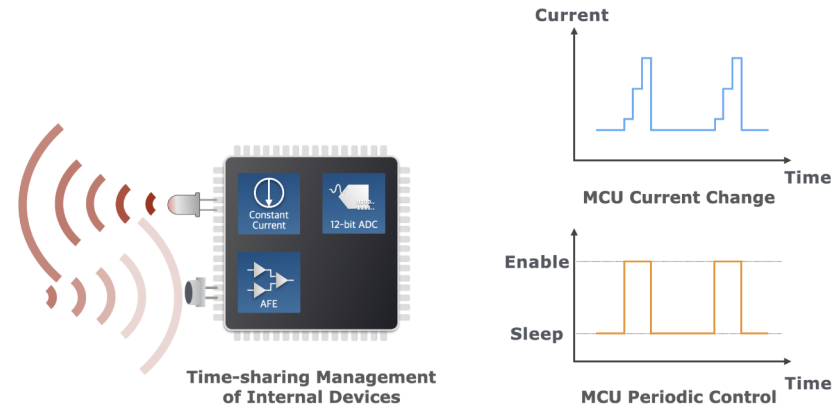

Figure 6. MCU Time-sharing Management for Low Power Consumption Technology

- MCU time-sharing management of internal components on/off, to accurately control product Sleep cycle and reduce product power consumption (Figure 6)
- Stand-alone smoke detector with a 10-year battery life

## Smoke Detection Series

### Enhanced Type Features

- Dual-input AFE circuit supports dual-channel transmission and dual-channel reception
- Integrated temperature sensor
- LXT (Calculate sensor life)
- Reduces standby current and extends battery life
- Improved HIRC 8MHz accuracy

Smoke Detection Series Features	General Type	Enhanced Type
AFE circuit	Dual-channel transmission and single-channel reception	Dual-channel transmission and dual-channel reception
Temperature sensor	–	Integrated
LXT	–	✓ (Calculate sensor life)
Standby current	High	Low
HIRC 8MHz accuracy	Low	High

## Power Line Transceiver Smoke Detection/Fire Protection Peripheral Series

### Product Features

- Support external fire protection dual-line bus communication circuit
- Integrated bus reception circuit, constant current transmission circuit
- Integrated 3.3V LDO

## Power Line Transceiver Smoke Detection/Fire Protection Peripheral Series

### Enhanced Type Features

- Integrated fire protection dual-line bus communication circuit with non-polar ( $\pm 42V$ ) input
- Added auto load and bus voltage follower functions
- Integrated 3.3V / 5.0V dual LDO

Power Line Transceiver Smoke Detection/Fire Protection Peripheral Series Features	General Type	Enhanced Type
Power Line Transceiver circuit	+42V (42V High-Side NMOS)	Non-polar ( $\pm 42V$ )
Bus reception, constant current transmission	✓	✓
LDO	3.3V LDO	3.3V/5V LDO
Auto load, bus voltage follower	–	✓



## Product Series Applications

### BA45F252xx Series General Purpose

- Suitable for 3V battery powered products

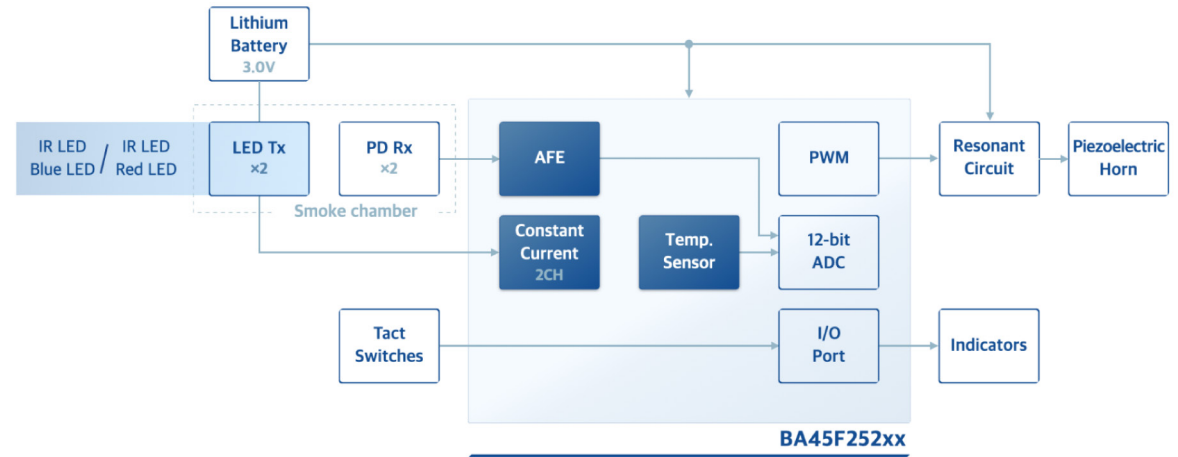

Figure 7. BA45F252xx Series General Purpose Type Application Block Diagram

### BA45F253xx Series Boost Type

- Suitable for 3V battery products
- Integrated Boost & Buzzer Driver, directly drive the 9V buzzer using the Boost circuit conversion

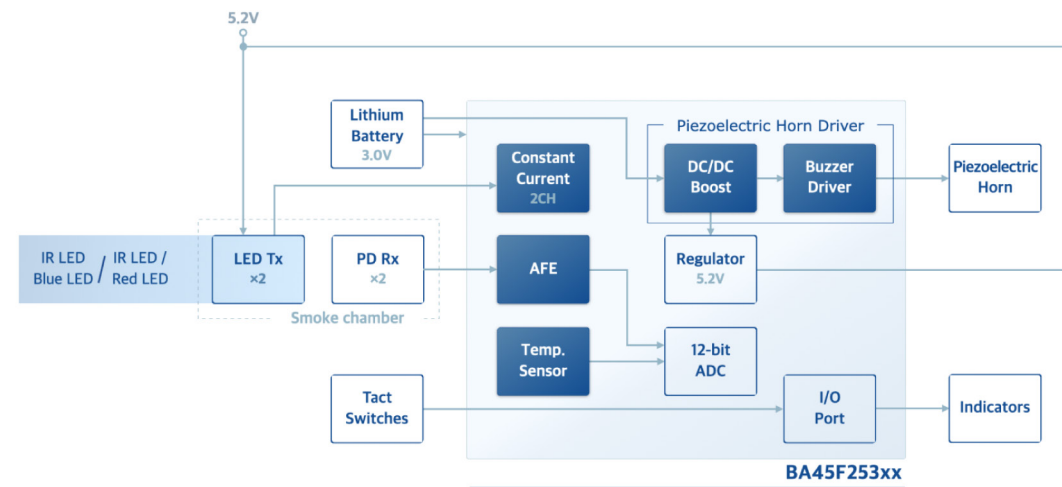

Figure 8. BA45F253xx Series Boost Type Application Block Diagram

## BA45F54xx Series Buck Type

- Suitable for 9V battery products
- Integrated 3.3V LDO to provide MCU operating voltage
- Integrated Buzzer Driver, the Piezoelectric Horn Driver drives the buzzer directly via battery voltage

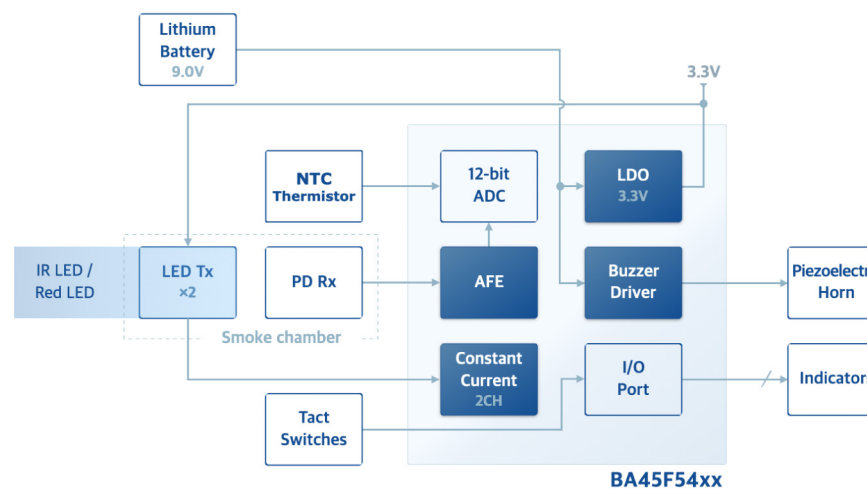

Figure 9. BA45F54xx Series Buck Type Application Block Diagram

## BA45F55xx Series Wired Networking Type

- Suitable for wired networking smoke detection products
- Power Line Transceiver & 42V High-Side NMOS for dual-line bus current transmission
- Integrated 3.3V LDO

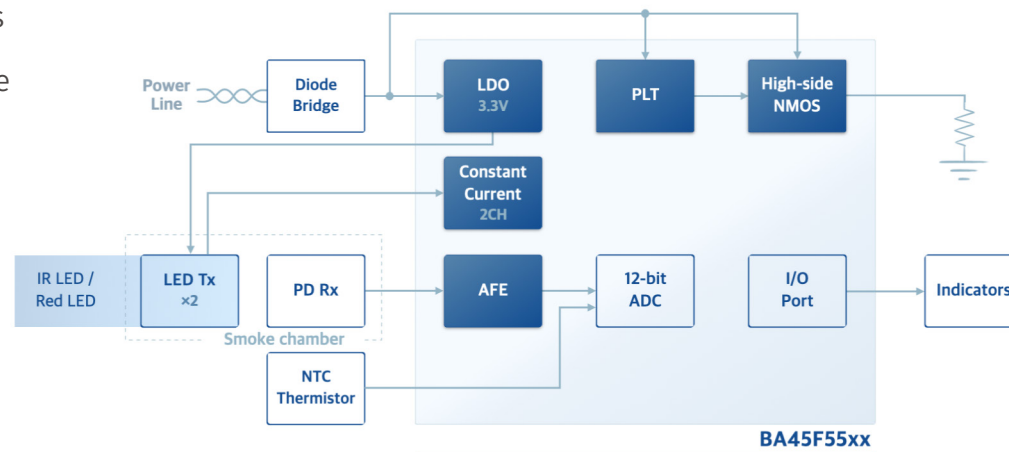

Figure 10. BA45F55xx Series Wired Networking Type Application Block Diagram

## BA45F255xx Series Enhanced Wired Networking Type

- Integrated fire protection dual-line bus communication circuit with non-polar ( $\pm 42V$ ) input
- Integrated 3.3V / 5V LDO
- PLT circuit with integrated auto discharge circuit

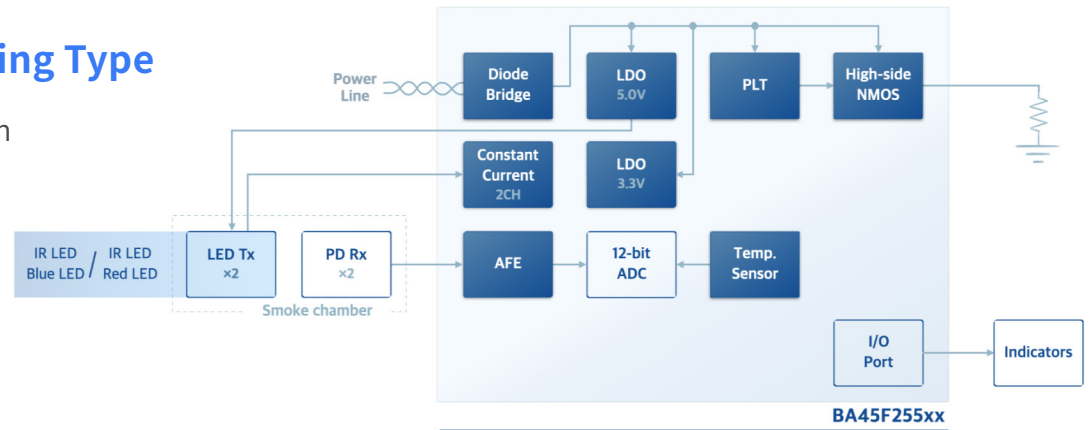

Figure 11. BA45F255xx Series Enhanced Type Application Block Diagram

## BA45F56xx Series Wireless Networking Type

- Suitable for wireless networking products
- Sub-1GHz supports 315/433/470/868/915MHz
- Maximum TX power 13dBm
- Maximum RX sensitivity (2kbps) -119dBm @433MHz
- Receiving power consumption (50kbps) 4.2mA

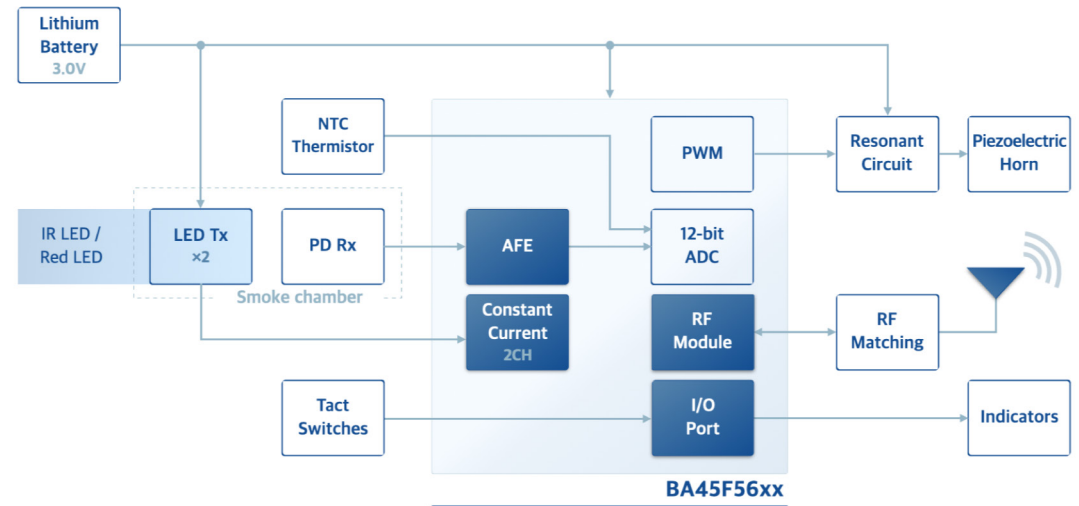

Figure 12. BA45F56xx Series Wireless Networking Type

## BA45F3xxx Fire Protection Peripheral Series

- Suitable for input/output modules, manual call points, sounder strobes, emergency lights, evacuation indicators and fire doors
- Power Line Transceiver & 42V High-Side NMOS for dual-line bus current transmission
- Integrated 3.3V LDO

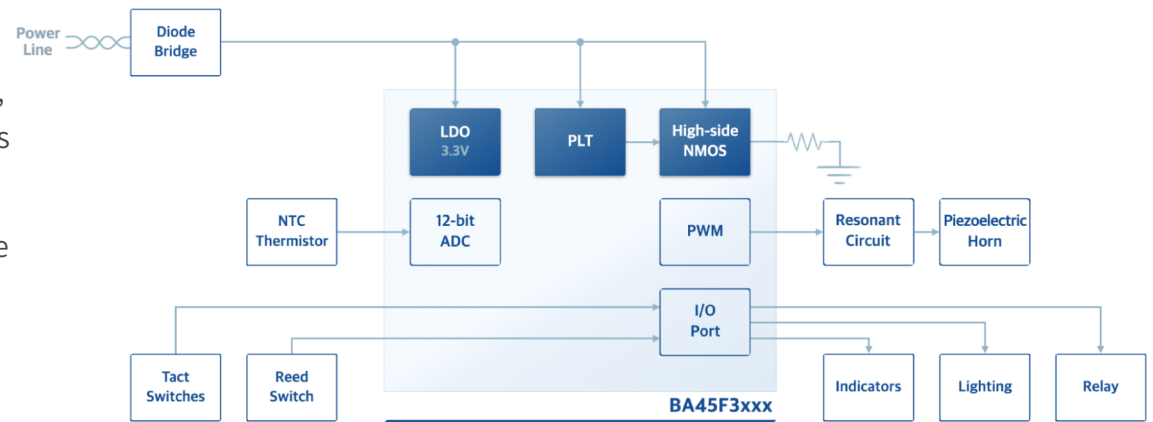

Figure 13. BA45F3xxx Fire Protection Peripheral Series Application Block Diagram

## BA45F5xxx Smoke Detector Workshop

The Smoke Detector Workshop is designed for the Holtek BA45F5240/BA45F5240-2 devices to generate initialisation code. They are suitable for use in photoelectric smoke detection products. The platform can be used to configure the clock, I/O and various peripheral functions of the MCU, and also includes hardware standby power consumption evaluation, AFE parameter debug function, etc. By proper use, the Smoke Detector Workshop can reduce the development time thus shortening the development period of smoke detection products.

### Features

- Graphical interface for setting MCU clock, I/O, ADC, communication serial port and other peripheral functions as well as AFE parameter debugging, standby power consumption evaluation and other functions to assist the initial development of smoke detector products.
- Generate MCU programming files, including smoke alarm detection, low battery voltage detection, battery internal resistance detection, IR tube fault detection, key-triggered self-check, temperature compensation, voltage compensation, etc., in line with the certification requirements of various countries.
- Debug mode can adjust the parameters including AFE circuit amplification gain, IR transmission current, transmission time and alarm threshold. It also provides smoke detection chamber and infrared tube test, repeatedly adjusting to verify the product smoke detection performance.
- The platform can generate software project file for secondary development and customize according to product requirements.

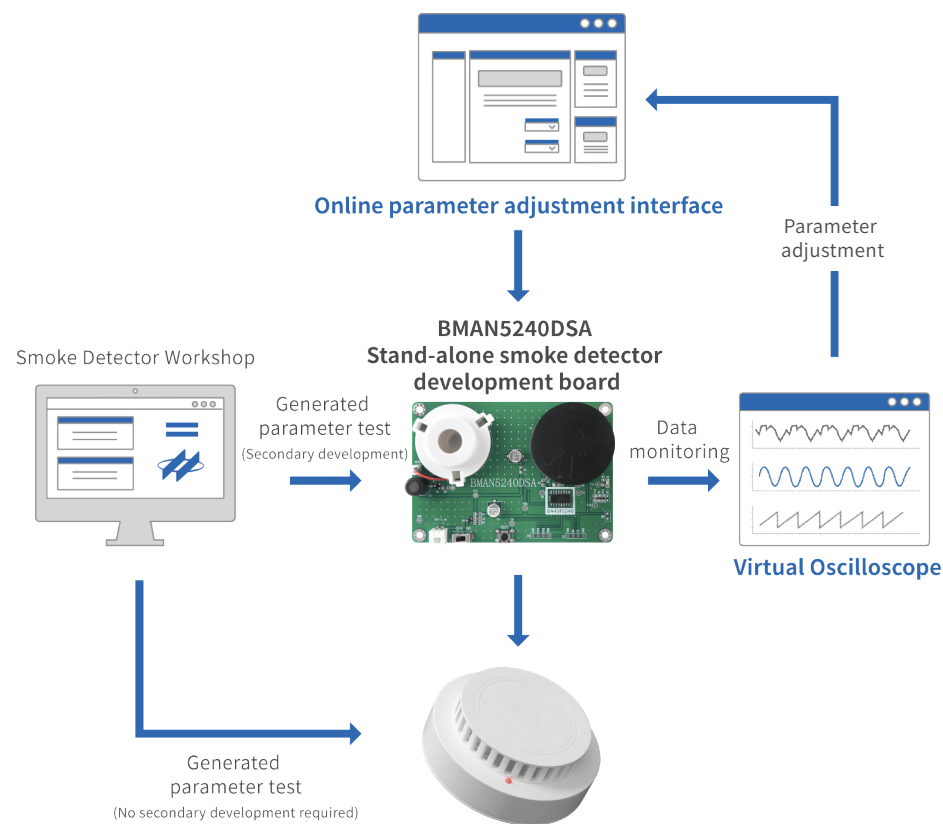
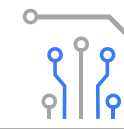

Figure 14. Smoke Detector Workshop Development Process

# Fire Protection/Smoke Detector Application Notes & Solutions



## Application Notes



## Application Solutions

### [BA45F56xx Wireless Transceiver Application](#)

Introduces the BA45F56xx series of MCUs, which includes an explanation of the Sub-1GHz RF Transceiver control flow and programming examples.

### [Strategies for BA45F25543 to Improve Fire Protection Dual-line Bus Communication Reliability](#)

Introduces PLT applications and the strategies for improving communication reliability.

### [BA45F25xxx Smoke Detector Integrated Analog Front End Application Notes](#)

Introduces dual-channel reception smoke detector AFE circuit principles.

### [BA45F25xxx Integrated Temperature Sensor Application Guidelines](#)

Describes how to setup the A/D converter temperature sampling and considerations when implementing temperature sampling and calibration.

### [Independent Smoke Detector Alarm](#)

#### [Voice Smoke Detector Alarm](#)

#### [Independent Siren Smoke Detector Alarm](#)

#### [9V Stand-alone Smoke Detector Alarm](#)

The Holtek stand-alone smoke detector solutions utilise the BA45Fx5xxx series

- Self-check, fault, alarm, battery under voltage and other status prompt functions
- Highly integrated smoke detection application circuit, eliminating the need for extra components
- The signal magnification can be adjusted by software to improve the signal sensitivity
- A dual-channel IR transmitting driver circuit meets the requirements of dual-transmission and dual-reception
- The ability to operate and switch dynamically between a range of operating modes gives users the ability to minimise power consumption

#### [Low Power Inter-connectable Smoke Detector Alarm](#)

The Holtek low power inter-connectable smoke detector alarm solution utilises the BA45F56xx series

- Implement smoke detection and group inter-connectable alarm functions
- The BA45F5640 includes a highly integrated smoke detection application circuit
- Sub-1GHz RF transceiver circuit
- Includes an internal smoke detector AFE and a dual-channel IR transmitting driver circuit
- The integrated RF transceiver has features including high power (+13dBm), high sensitivity (-119dBm@2Kbps) and low power consumption
- The transceiver can operate in the Sub-1GHz ISM frequency bands (300~960MHz), and also provides an auto-transmit-receive (ATR) function

# Fire Protection/Smoke Detector MCU Selection Guide

Please refer to the official website for product selection information.

Smoke Detector Flash MCU	Part No.	Max. Freq.	VDD	Program Memory	Data Memory	Data EEPROM	IAP	I/O	Timer	ADC	Voice DAC	AFE	IR Driver	Temp. Sensor	Interface	Package
	BA45F5220	8MHz	2.2V~5.5V	1K×14	64×8	32×14	—	4	10-bit PTM×1	10-bit ×3	—	1CH	2	—	—	8SOP 10SOP
	BA45F5240	8MHz	2.2V~5.5V	4K×16	256×8	64×8	—	13	10-bit PTM×1 10-bit STM×1	12-bit ×4	—	1CH	2	—	UART/SPI/I <sup>2</sup> C×1	16NSOP 20SSOP
	BA45F5240-2							11								16NSOP
	BA45F5250	8MHz	2.2V~5.5V	8K×16	1024×8	128×8	√	22	10-bit PTM×1 10-bit STM×2	12-bit ×8	16-bit ×1	1CH	2	—	UART×1 SPI/I <sup>2</sup> C×1	16NSOP 20/24/28SSOP
	BA45F5260	16MHz	2.2V~5.5V	16K×16	2048×8	256×8	√	26	10-bit PTM×3 10-bit STM×2	12-bit ×12	16-bit ×1	1CH	2	√	UART×2 SPI/I <sup>2</sup> C×1	24/28SSOP 48LQFP

Enhanced Smoke Detector Flash MCU	Part No.	Max. Freq.	VDD	Program Memory	Data Memory	Data EEPROM	IAP	CRC	I/O	Timer	ADC	Voice DAC	AFE	IR Driver	Temp. Sensor	Interface	Package
	BA45F25240	8MHz	2.2V~5.5V	4K×16	256×8	64×8	—	√	15	10-bit PTM×1 10-bit STM×1	12-bit ×4	—	2CH	2	√	UART/SPI/I <sup>2</sup> C×1	16NSOP 20/24SSOP
	BA45F25240-2								11								16NSOP
	BA45F25250	8MHz	2.2V~5.5V	8K×16	1024×8	128×8	√	√	22	10-bit PTM×1 10-bit STM×2	12-bit ×8	16-bit ×1	2CH	2	√	UART×1 SPI/I <sup>2</sup> C×1	16NSOP 20/24/28SSOP
	BA45F25260	16MHz	2.2V~5.5V	16K×16	2048×8	256×8	√	√	31	10-bit PTM×3 10-bit STM×2	12-bit ×16	16-bit ×1	2CH	2	√	UART×2 SPI/I <sup>2</sup> C×1	28SSOP 48LQFP

Smoke Detector Flash MCU with Buzzer Driver	Part No.	Max. Freq.	VDD	Program Memory	Data Memory	Data EEPROM	IAP	I/O	Timer	ADC	Voice DAC	AFE	IR Driver	Temp. Sensor	Boost	Interface	Package
	BA45F5320	8MHz	2.2V~5.5V	1K×14	64×8	32×14	—	4	10-bit PTM×1	10-bit ×3	—	1CH	2	—	√	—	20SSOP
	BA45F5340	8MHz	2.2V~5.5V	4K×16	256×8	64×8	—	13	10-bit PTM×1 10-bit STM×1	12-bit ×4	—	1CH	2	—	√	UART/SPI/I <sup>2</sup> C×1	24SSOP 28SSOP
	BA45F5350	8MHz	2.2V~5.5V	8K×16	1024×8	128×8	√	22	10-bit PTM×1 10-bit STM×2	12-bit ×8	16-bit ×1	1CH	2	—	√	UART×1 SPI/I <sup>2</sup> C×1	28SSOP 48LQFP
	BA45F5360	16MHz	2.2V~5.5V	16K×16	2048×8	256×8	√	26	10-bit PTM×3 10-bit STM×2	12-bit ×12	16-bit ×1	1CH	2	√	√	UART×2 SPI/I <sup>2</sup> C×1	28SOP 48LQFP

Enhanced Smoke Detector Flash MCU with Buzzer Driver	Part No.	Max. Freq.	VDD	Program Memory	Data Memory	Data EEPROM	IAP	CRC	I/O	Timer	ADC	Voice DAC	AFE	IR Driver	Temp. Sensor	Boost	Interface	Package
	BA45F25343	8MHz	2.2V~5.5V	4K×16	256×8	64×8	—	√	12	10-bit PTM×1 10-bit STM×1	12-bit ×4	—	2CH	2	√	√	UART/SPI/I <sup>2</sup> C×1	24SSOP 28SSOP
	BA45F25353	8MHz	2.2V~5.5V	8K×16	1024×8	128×8	√	√	22	10-bit PTM×1 10-bit STM×2	12-bit ×8	16-bit ×1	2CH	2	√	√	UART×1 SPI/I <sup>2</sup> C×1	28SOP 48LQFP
	BA45F25363	16MHz	2.2V~5.5V	16K×16	2048×8	256×8	√	√	31	10-bit PTM×3 10-bit STM×2	12-bit ×16	16-bit ×1	2CH	2	√	√	UART×2 SPI/I <sup>2</sup> C×1	48LQFP

9V Battery Smoke Detector MCU with Buzzer Driver	Part No.	Max. Freq.	VCC (HV)	Program Memory	Data Memory	Data EEPROM	IAP	I/O	Timer	ADC	Voice DAC	AFE	IR Driver	Temp. Sensor	LDO	Buzzer Driver	Interface	Package
	BA45F5420	8MHz	4.3V~12V	1K×14	64×8	32×14	—	4	10-bit PTM×1	10-bit ×3	—	1CH	2	—	√	√	—	16NSOP
	BA45F5440	8MHz	4.3V~12V	4K×16	256×8	64×8	—	9	10-bit PTM×1 10-bit STM×1	12-bit ×4	—	1CH	2	—	√	√	UART/SPI/I <sup>2</sup> C×1	20SOP 20SSOP
	BA45F5450	8MHz	4.3V~12V	8K×16	1024×8	128×8	√	17	10-bit PTM×1 10-bit STM×2	12-bit ×8	16-bit ×1	1CH	2	—	√	√	UART×1 SPI/I <sup>2</sup> C×1	20SOP 24/28SOP
	BA45F5460	16MHz	4.3V~12V	16K×16	2048×8	256×8	√	24	10-bit PTM×3 10-bit STM×2	12-bit ×12	16-bit ×1	1CH	2	√	√	√	UART×2 SPI/I <sup>2</sup> C×1	48LQFP

Please refer to the official website for product selection information.

Smoke Detector Flash MCU with Addressable Power Line Transceiver	Part No.	Max. Freq.	VCC (HV)	Program Memory	Data Memory	Data EEPROM	IAP	I/O	Timer	ADC	AFE	IR Driver	Power Line Transceiver	LDO	Temp. Sensor	Interface	Package
	BA45F5542	8MHz	42V	4K×16	256×8	64×8	—	9	10-bit PTM×1 10-bit STM×1	12-bit ×4	1CH	2	√	√	—	UART/SPI/I <sup>2</sup> C×1	16NSOP 20SSOP
	BA45F5542-2							7		12-bit ×3							16NSOP
	BA45F5552	8MHz	42V	8K×16	1024×8	128×8	√	13	10-bit PTM×1 10-bit STM×2	12-bit ×8	1CH	2	√	√	—	UART×1 SPI/I <sup>2</sup> C×1	16NSOP 20/24SOP
	BA45F5562	16MHz	42V	16K×16	2048×8	256×8	√	23	10-bit PTM×3 10-bit STM×2	12-bit ×12	1CH	2	√	√	√	UART×2 SPI/I <sup>2</sup> C×1	24SOP, 28SOP 28SSOP, 48LQFP



Enhanced Smoke Detector Flash MCU with Addressable Power Line Transceiver	Part No.	Max. Freq.	VCC (HV)	Program Memory	Data Memory	Data EEPROM	IAP	CRC	I/O	Timer	ADC	AFE	IR Driver	Power Line Transceiver	LDO	Temp. Sensor	Interface	Package
	BA45F25543	8MHz	±42V <sup>#</sup>	4K×16	256×8	64×8	—	√	10	10-bit PTM×1 10-bit STM×1	12-bit ×4	2CH	2	√	3.3V 5.0V	√	UART/SPI/I <sup>2</sup> C×1	16NSOP 24SSOP
	BA45F25553	8MHz	±42V <sup>#</sup>	8K×16	1024×8	128×8	√	√	13	10-bit PTM×1 10-bit STM×2	12-bit ×8	2CH	2	√	3.3V 5.0V	√	UART×1 SPI/I <sup>2</sup> C×1	16NSOP 28SOP
	BA45F25563	16MHz	±42V <sup>#</sup>	16K×16	2048×8	256×8	√	√	28	10-bit PTM×3 10-bit STM×2	12-bit ×16	2CH	2	√	3.3V 5.0V	√	UART×2 SPI/I <sup>2</sup> C×1	28SOP 48LQFP

Note: # Built-in MOSFET bridge rectifier can achieve non-polar voltage input.

Smoke Detector Flash MCU with Sub-1GHz Transceiver	Part No.	Max. Freq.	VDD	Program Memory	Data Memory	Data EEPROM	IAP	I/O	Timer	ADC	AFE	IR Driver	Band	Data Rate	Output Power	Temp. Sensor	Interface	Package
	BA45F5640	8MHz	2.2V~ 3.6V	4K×16	256×8	64×8	—	13	10-bit PTM×1 10-bit STM×1	12-bit ×4	1CH	2	315MHz 433MHz 470MHz 868MHz 915MHz	2~250 kbps	13dBm	—	UART/SPI/I <sup>2</sup> C×1	46QFN
	BA45F5650			8K×16	1024×8	128×8	√	17	10-bit PTM×1 10-bit STM×2	12-bit ×5							UART×1 SPI/I <sup>2</sup> C×1	
	BA45F5660			16K×16	2048×8	256×8		22	10-bit PTM×3 10-bit STM×2	12-bit ×8							√	UART×2 SPI/I <sup>2</sup> C×1

Fire Protection Flash MCU with Power Line Transceiver	Part No.	Max. Freq.	VCC (HV)	VDD	Program Memory	Data Memory	Data EEPROM	IAP	CRC	I/O	Timer	ADC	Power Line Transceiver	LDO	Interface	Package
BA45F3541	8MHz	42V	3.3V	4K×16	256×8	512×8	√	√	13	10-bit PTM×2 10-bit CTM×4	12-bit×4	√	√	UART×1	16NSOP 20SSOP	

## Module/Development Board

Appearance	Part No.	Module/Development Board	Functional Description
	BA45F5220	BMAN5220DSA	Smoke Detection Alarm
	BA45F5240	BMAN5240DSA	
		BMAN5240DSC	
	BA45F5250	BMAN5250DSB	NB-IoT Smoke Alarm
		BMAN5250DSC	Smoke Detection Alarm
	BA45F5260	BMAN5260DSB	NB-IoT Smoke Alarm
	BA45F25240	BMAN25240DSA	Smoke Detection Alarm
	BA45F5320	BMAN5320DSA	Smoke Alarm with 12V Piezoelectric Horn Driver
	BA45F5340/50	BMAN53x0DSA	
	BA45F5360	BMAN5360DSA	
	BA45F5420	BMAN5420DSA	9V High Voltage Smoke Detection Alarm
	BA45F54x0	BMAN54x0DSA	Smoke Detection Alarm
	BA45F5440	BMAN5440DSB	9V High Voltage Smoke Detection Alarm
	BA45F5542	BMAN5542DSA	Networked Smoke Alarm
BA45F5562	BMAN5562DSA		
BA45F25543	BMAN25543DSA		
	BM22S2021-1	—	Digital Smoke Detection Sensor Module

\* Contact your business unit for DEMO development board requirements

# CO/GAS/PIR Series Introduction

## Introduction

Holtek provides CO/GAS environmental detection dedicated MCU series. These devices contain fully integrated CO/GAS detection main circuits, making them suitable for electrochemical, catalytic combustion, semiconductor CO/GAS and other gas detection sensors. The series of MCUs also integrate the related functions required by these products, such as voice, LCD driver, temperature compensation, data recording, communication interface, combined (smoke and CO/GAS) detection, to meet the full range of customer product requirements.

In terms of human body movement detection, Holtek provides PIR detection dedicated MCU series, which includes fully integrated PIR detection filter, amplifier circuit and temperature compensation, communication interface and other related product required functions, providing dedicated MCUs with high reliability and high integration that reduce peripheral components and improve production efficiency and consistency.

## CO Detection Principle

An electrochemical CO sensor is a device used to detect the CO concentration in the air. The operating principle is that when CO enters the sensor, an electrochemical reaction will occur internally, which will produce a current proportional to the CO concentration. The higher the CO content in the environment, the greater the current. The higher the environmental CO concentration level, the greater the current. This current can be measured to accurately reflect the CO concentration, as shown in Figure 15.

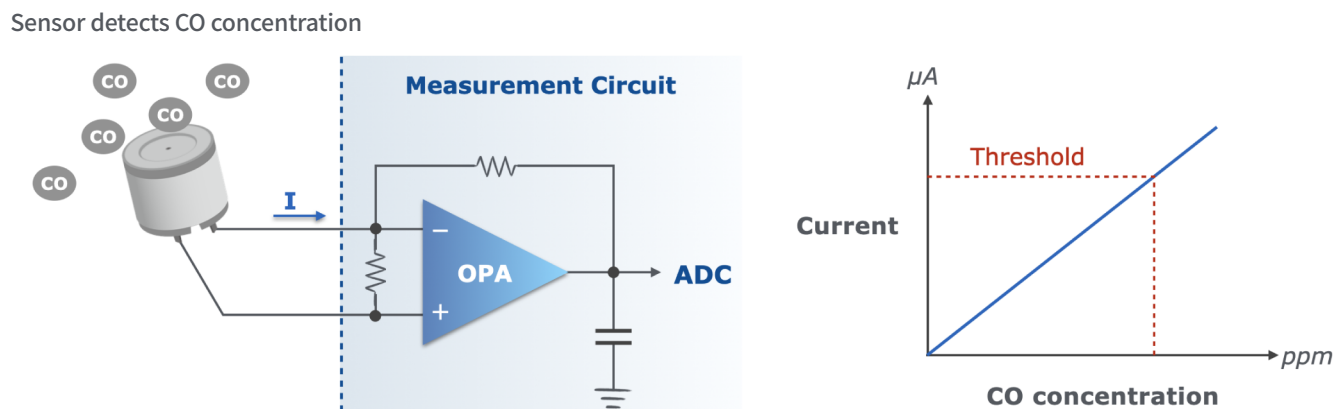

Figure 15. CO Detection Principle

## GAS Detection Principle

### ● Catalytic Combustion Sensor

A catalytic combustion sensor is a device used to detect the combustible gas concentration in the air. The operating principle is that when gases enter the sensor, they will interact with the catalyst to produce combustion and generate heat, which will change the resistance value inside the sensor and generate a voltage signal. To measure this voltage signal, a simple measurement circuit is required. By measuring the voltage signal, the environmental gas concentration can be obtained. The higher the gas concentration level, the greater the voltage change, as shown in Figure 16. The sensor has high sensitivity, high accuracy, fast response, high stability and good anti-interference ability. However, it consumes an amount of power, requires oxygen and has a limited life and a high cost.

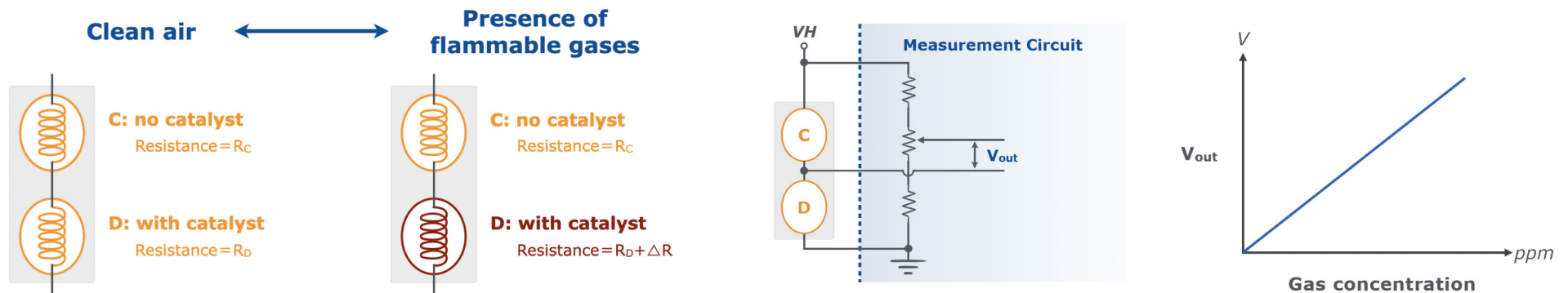

Figure 16. Catalytic Combustion Sensor Detection Principle

## ● Semiconductor Sensor

A semiconductor sensor uses tin dioxide material ( $\text{SnO}_2$ ) with low conductivity in clean air as a gas-sensitive material. When combustible gases are present in the environment where the sensor is located, the sensor conductivity will increase according to the gas concentration level in the air, as shown in Figure 17. This sensor has low cost, long service life and low power consumption. But the sensitivity and accuracy are relatively low.

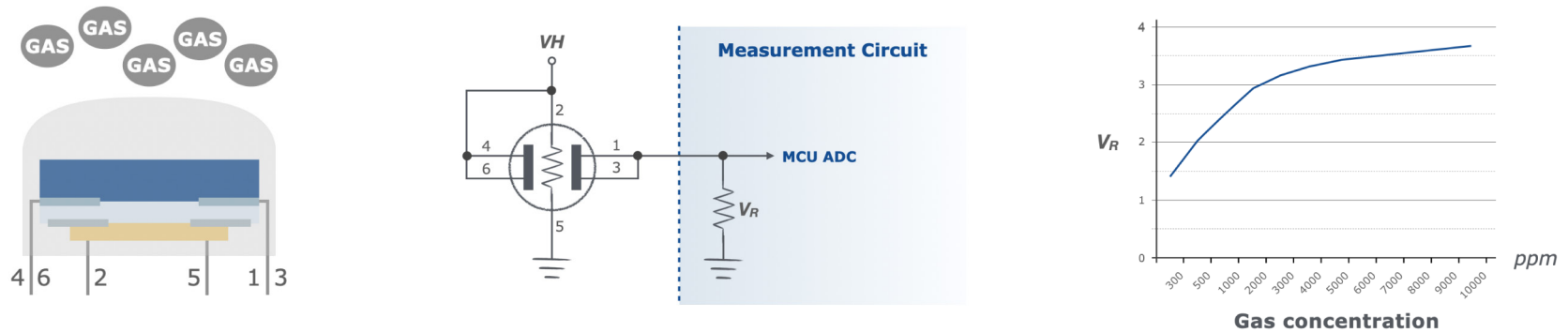

Figure 17. Semiconductor Sensor Detection Principle

## PIR Detection Principle

The Passive Infra-Red (PIR) technology is used to detect human body movement signals. It uses a pyroelectric sensor to optically detect infrared with a wavelength range of  $8\sim 14\mu\text{m}$ , to generate output voltage fluctuation signals. Combined with relevant processing such as filtering, amplification, signal conversion capture, and PIR trigger determination, the human body movement detection can be implemented as shown in Figure 18.

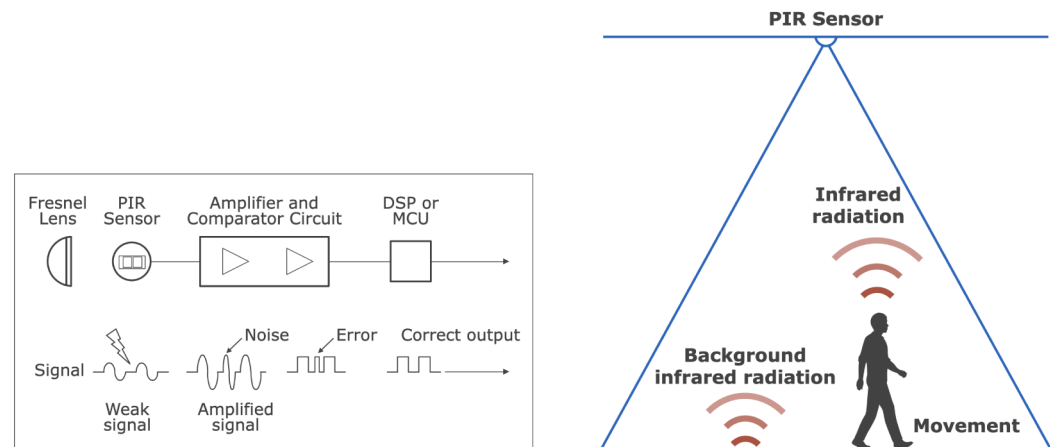

Figure 18. PIR Detection Principle

## Product Series

At present, the common GAS sensors are catalytic combustion and semiconductor sensors, and the CO sensors are mainly electrochemical sensors. Holtek has released CO/GAS detector MCUs to meet the needs of different sensors. The full range of CO/GAS/PIR dedicated MCUs have high integration, reducing peripheral components and improving production efficiency and consistency.

### CO/GAS/PIR detection dedicated MCUs are divided into:

- CO (electrochemical) / GAS (catalytic combustion) detection series BA45F67xx
- Smoke and CO/GAS combined detection series BA45F69xx
- GAS (semiconductor) detection series BA45F67x3
- PIR detection series BA45F66xx

Customers can select the series according to the electrochemical and semiconductor characteristics of the sensor, and then select the MCU part number according to other product requirements, such as voice or buzzer alarm, LCD or LED display, event recording, communication interface, combined measurement and other detailed requirements.

	1KW	2KW	4KW	8KW	16KW	
<b>General Purpose</b> <b>BA45F67xx</b>		BA45F6730	BA45F6740 ● BA45F6746	● BA45F6750 ●● BA45F6756	● BA45F6760 ●● BA45F6766	Electrochemical CO
<b>Event Recording</b> <b>BA45F67xx</b>			BA45F6742 ● BA45F6748	● BA45F6752 ●● BA45F6758	● BA45F6762 ●● BA45F6768	Catalytic Combustion GAS
<b>Semiconductor Event Recording</b> <b>BA45F67x3</b>				BA45F6753	BA45F6763	Semiconductor GAS
<b>PIR &amp; Microwave</b> <b>BA45F66xx</b>	BA45F6622	BA45F6630				PIR & Microwave

● with LCD Driver  
●● with Voice DAC

Figure 19. CO/GAS/PIR Detection MCU Selection Guide

## BA45F67xx CO (Electrochemical) / GAS (Catalytic combustion) Series

- Suitable for electrochemical and catalytic combustion gas detection products
- Integrated CO (electrochemical) / GAS (catalytic combustion)
- Integrated temperature sensor
- LED/LCD display driver and buzzer/voice alarm functions
- Calendar and alarm event recording functions

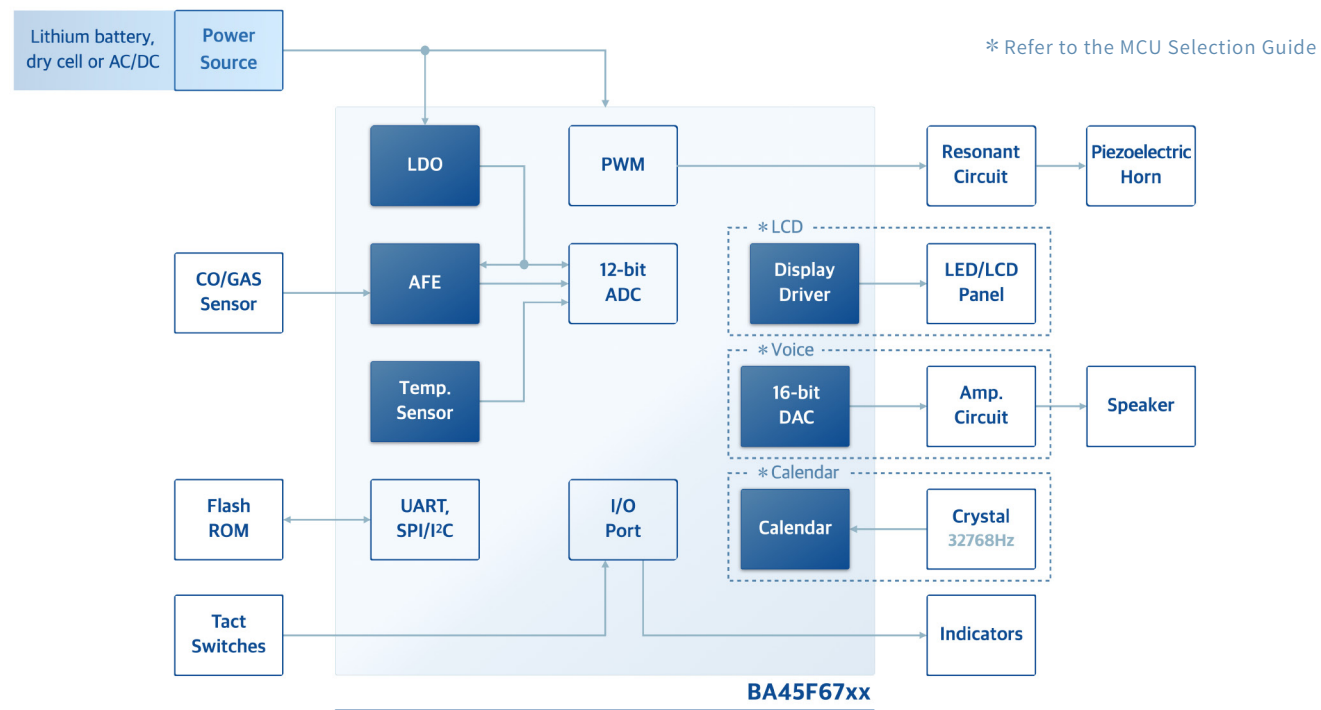

Figure 20. CO (Electrochemical) / GAS (Catalytic Combustion) Detector Application Block Diagram

## BA45F67x3 GAS (Semiconductor) Series

- Suitable for semiconductor gas detection products
- Integrated 12-bit A/D Converter circuit for GAS (semiconductor) detection
- Calendar function
- Communication interface functions

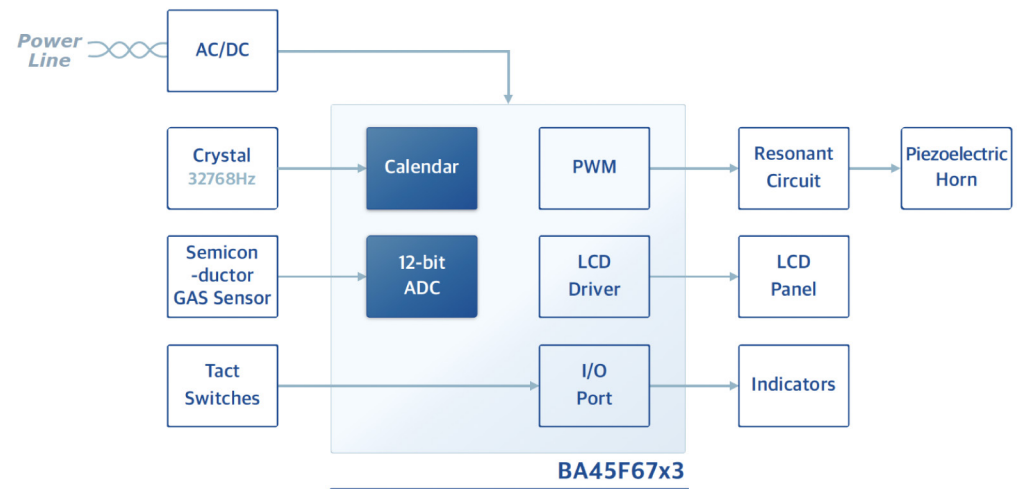

Figure 21. GAS (Semiconductor) Detector Application Block Diagram

## BA45F66xx PIR Series

- Suitable for human body movement detection products
- Integrated PIR detection AFE circuit
- Communication interface functions
- Integrated auto conversion circuit enables the MCU to detect PIR signals in Sleep mode and maintain low power consumption

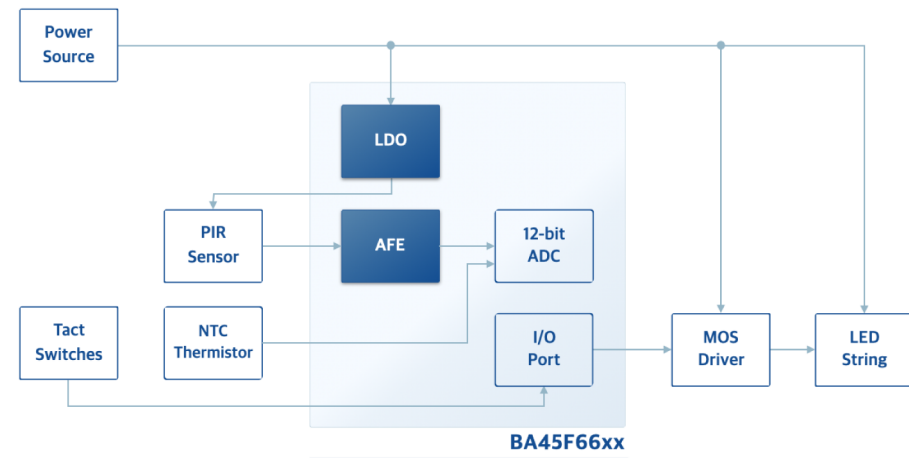

Figure 22. BA45F66xx PIR Sensor Light Application Block Diagram

# CO/GAS/PIR Detector Application Notes & Solutions



## Application Notes

### [BA45F66xx Integrated PIR with Analog Front End and Microwave Application Guideline](#)

Introduces the application guidelines of the BA45F66xx MCUs for PIR and microwave products

### [HOLTEK CO/GAS Detector MCU Application Note](#)

Introduces the circuit principles and application instructions of the CO/GAS detector MCUs

### [BA45F67xx Calendar Application Note](#)

Application note for the historical record function of the CO/GAS detector MCU series

### [Holtek CO/GAS Detector MCUs for Temperature Compensation Application](#)

Application note for the temperature compensation method of the CO/GAS detector MCUs

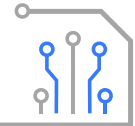

## Application Solutions

### [Stand-alone CO Detector Alarm](#)

### [Stand-alone CO Detector with LCD](#)

CO/GAS Detector Series Features:

- Integrated CO/GAS detector, includes an OPA and an adjustable feedback resistor which helps to eliminate many external components when compared with traditional solutions
- Integrated temperature sensor, used for temperature compensation to improve the product environmental adaptability
- 12-bit A/D converter, used to convert the present CO concentration data in real time
- Integrated LDO, provides multiple stable voltage outputs to reduce power fluctuations
- Integrated LCD display driver and hardware calendar for event recording
- Various communication interfaces, provide a comprehensive range functions required by CO detectors

# CO/GAS/PIR Detector MCU Selection Guide

Please refer to the official website for product selection information.

CO/GAS(Catalytic Gas Sensor) Detector Flash MCU	Part No.	Max. Freq.	VDD	Program Memory	Data Memory	Data EEPROM	Stack	IAP	I/O	Timer	ADC	AFE	Temp. Sensor	Voice DAC	Interface	Package
	BA45F6730	8MHz	2.2V~5.5V	2K×16	128×8	32×8	6	—	14	10-bit PTM×1 10-bit STM×1	12-bit×5	√	—	—	UART/SPI/I <sup>2</sup> C×1	16NSOP, 20SSOP
	BA45F6740	8MHz	2.2V~5.5V	4K×16	256×8	128×8	8	√	22	10-bit PTM×1 10-bit STM×1	12-bit×8	√	√	—	UART/SPI/I <sup>2</sup> C×1	16NSOP, 20SSOP 24SSOP, 28SSOP
	BA45F6750	8MHz	2.2V~5.5V	8K×16	1024×8	256×8	8	√	36	10-bit PTM×1 10-bit STM×1	12-bit×8	√	√	16-bit ×1	UART×1 UART/SPI/I <sup>2</sup> C×1	28SSOP 32QFN, 48LQFP
	BA45F6760	8MHz	2.2V~5.5V	16K×16	2024×8	256×8	8	√	42	10-bit PTM×1 10-bit STM×2	12-bit×8	√	√	16-bit ×1	UART×1 UART/SPI/I <sup>2</sup> C×1	28SSOP 48LQFP

CO/GAS(Catalytic Gas Sensor) Detector Flash LCD MCU	Part No.	Max. Freq.	VDD	Program Memory	Data Memory	Data EEPROM	Stack	IAP	I/O	Timer	ADC	AFE	LCD Driver	Temp. Sensor	Voice DAC	Interface	Package
	BA45F6746	8MHz	2.2V~5.5V	4K×16	256×8	128×8	8	√	31	10-bit PTM×1 10-bit STM×1	12-bit ×8	√	12SEG ×4COM	√	—	UART/SPI/I <sup>2</sup> C×1	28SSOP 32QFN, 48LQFP
	BA45F6756	8MHz	2.2V~5.5V	8K×16	1024×8	256×8	8	√	36	10-bit PTM×1 10-bit STM×1	12-bit ×8	√	16SEG ×4COM	√	16-bit ×1	UART×1 UART/SPI/I <sup>2</sup> C×1	28SSOP 48LQFP
	BA45F6766	8MHz	2.2V~5.5V	16K×16	2048×8	256×8	8	√	38	10-bit PTM×1 10-bit STM×2	12-bit ×8	√	20SEG ×4COM	√	16-bit ×1	UART×1 UART/SPI/I <sup>2</sup> C×1	28SSOP 48LQFP

CO/GAS(Catalytic Gas Sensor) Detector Flash MCU with Calendar	Part No.	Max. Freq.	VDD	Program Memory	Data Memory	Data EEPROM	Stack	IAP	I/O	Timer	ADC	AFE	Temp. Sensor	Voice DAC	Interface	Package
	BA45F6742	8MHz	2.2V~5.5V	4K×16	256×8	128×8	8	√	22	10-bit PTM×1 10-bit STM×1	12-bit×8	√	√	—	UART/SPI/I <sup>2</sup> C×1	28SSOP 48LQFP
	BA45F6752	8MHz	2.2V~5.5V	8K×16	1024×8	256×8	8	√	31	10-bit PTM×1 10-bit STM×1	12-bit×8	√	√	16-bit ×1	UART×1 UART/SPI/I <sup>2</sup> C×1	48LQFP
	BA45F6762	8MHz	2.2V~5.5V	16K×16	2048×8	256×8	8	√	31	10-bit PTM×1 10-bit STM×2	12-bit×8	√	√	16-bit ×1	UART×1 UART/SPI/I <sup>2</sup> C×1	48LQFP

GAS(Semiconductor Gas Sensor) Detector Flash MCU with Calendar	Part No.	Max. Freq.	VDD	Program Memory	Data Memory	Data EEPROM	Stack	IAP	I/O	Timer	ADC	Interface	Package
	BA45F6753	16MHz	2.2V~5.5V	8K×16	512×8	128×8	8	√	26	10-bit PTM×1 16-bit CTM×1 16-bit STM×1	12-bit×12	UART×1 SPI/I <sup>2</sup> C×1	28SSOP 48LQFP
	BA45F6763	16MHz	2.2V~5.5V	16K×16	1024×8	1024×8	8	√	28	10-bit PTM×2 16-bit CTM×1 16-bit STM×1	12-bit×12	UART×2 SPI/I <sup>2</sup> C×1	28SSOP 48LQFP

Please refer to the official website for product selection information.





<b>CO/GAS(Catalytic Gas Sensor) Detector Flash LCD MCU with Calendar</b>	<b>Part No.</b>	<b>Max. Freq.</b>	<b>VDD</b>	<b>Program Memory</b>	<b>Data Memory</b>	<b>Data EEPROM</b>	<b>Stack</b>	<b>IAP</b>	<b>I/O</b>	<b>Timer</b>	<b>ADC</b>	<b>AFE</b>	<b>LCD Driver</b>	<b>Temp. Sensor</b>	<b>Voice DAC</b>	<b>Interface</b>	<b>Package</b>
	BA45F6748	8MHz	2.2V~5.5V	4K×16	256×8	128×8	8	√	31	10-bit PTM×1 10-bit STM×1	12-bit ×8	√	12SEG ×4COM	√	—	UART/SPI/I <sup>2</sup> C×1	48LQFP
	BA45F6758	8MHz	2.2V~5.5V	8K×16	1024×8	256×8	8	√	32	10-bit PTM×1 10-bit STM×1	12-bit ×8	√	13SEG ×4COM	√	16-bit ×1	UART×1 UART/SPI/I <sup>2</sup> C×1	48LQFP
	BA45F6768	8MHz	2.2V~5.5V	16K×16	2048×8	256×8	8	√	32	10-bit PTM×1 10-bit STM×2	12-bit ×8	√	14SEG ×4COM	√	16-bit ×1	UART×1 UART/SPI/I <sup>2</sup> C×1	48LQFP

<b>PIR Flash MCU</b>	<b>Part No.</b>	<b>Max. Freq.</b>	<b>VDD</b>	<b>Program Memory</b>	<b>Data Memory</b>	<b>Data EEPROM</b>	<b>Stack</b>	<b>I/O</b>	<b>Timer</b>	<b>ADC</b>	<b>OPA</b>	<b>Interface</b>	<b>Package</b>
	BA45F6622	8MHz	2.2V~5.5V	1K×14	64×8	32×14	4	6	10-bit STM×1	10-bit×2	2	—	16NSOP 16QFN
	BA45F6630	8MHz	2.2V~5.5V	2K×16	256×8	32×8	6	15	10-bit STM×2	12-bit×4	2	UART/SPI/I <sup>2</sup> C×1	24SSOP 24QFN

## Module/Development Board

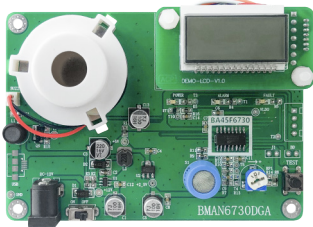
\*Contact your business unit for DEMO development board requirements

- Marked as expected planning DEMO development board

Appearance	Part No.	Module/Development Board	Functional Description
	<a href="#">BA45F6956</a>	<a href="#">BMAN6956DCA</a>	Smoke and CO/GAS Combined Alarm
	<a href="#">BA45F6730</a>	<a href="#">BMAN6730DGA</a>	Gas Detector
		<a href="#">BMAN6730DCA</a>	CO Alarm
	<a href="#">BA45F6746</a>	<a href="#">BMAN6746DCA</a>	Gas Detector
		<a href="#">BMAN6746DGA</a>	CO Alarm
	<a href="#">BA45F6756</a>	<a href="#">BMAN6756DCA</a>	CO Alarm with Calendar
	<a href="#">BA45F6748</a>	<a href="#">BMAN6748DCA</a>	Gas Detector with Calendar
		<a href="#">BMAN6748DCB</a>	CO Alarm with Calendar
		<a href="#">BMAN6748DGA</a>	Gas Detector with Calendar
	<a href="#">BA45F6758</a>	<a href="#">BMAN6758DCC</a>	CO Alarm with Calendar
	<a href="#">BA45F6753</a>	<a href="#">BMAN6753DGA</a>	Gas Detector with Calendar
		<a href="#">BMAN6753DGC</a>	
	<a href="#">BA45F6763</a>	<a href="#">BMAN6763DGA</a>	PIR Alarm
<a href="#">BA45F6622</a>	<a href="#">BMAN6622DPA</a>		
<a href="#">BA45F6630</a>	<a href="#">BMAN6630DPA</a>		
	<a href="#">BM22S3221-1</a>	—	Digital Electrochemical CO Detector
	<a href="#">BM22S3021-1</a>	—	GAS Detection Digital Sensor
	<a href="#">BM22S3031-1</a>	—	Digital Catalytic Combustion GAS Detection Sensor
	<a href="#">BM22S4221-1</a>	—	PIR Detection Digital Module

# Development Resources

## ⚙️ Online Debug Adaptor

The e-Link is an online debug adaptor for Holtek's OCDS architecture Flash MCUs. Together with the HT-IDE3000 software it allows users to program and debug programs on their target boards. It provides debug operations such as single step, full speed, stop, breakpoints during the debug process.

Hardware: [e-Link](#)  
Software: [HT-IDE3000](#)

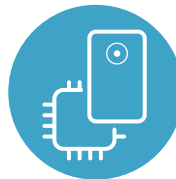

## ⚙️ Programmer

The e-WriterPro can be used as a programming tool for all of Holtek MCUs, supports both online and offline programming modes and can also be used for small to medium volume production purposes.

Hardware: [e-WriterPro](#)  
Software: [HOPE3000](#)



Holtek MCU	ICE	Programmer	Compatible Software
HT8	e-Link	e-WriterPro	HT-IDE3000/HOPE3000
HT32	e-Link32Pro	e-Writer32	Keil/HT32-IDE/HOPE3200

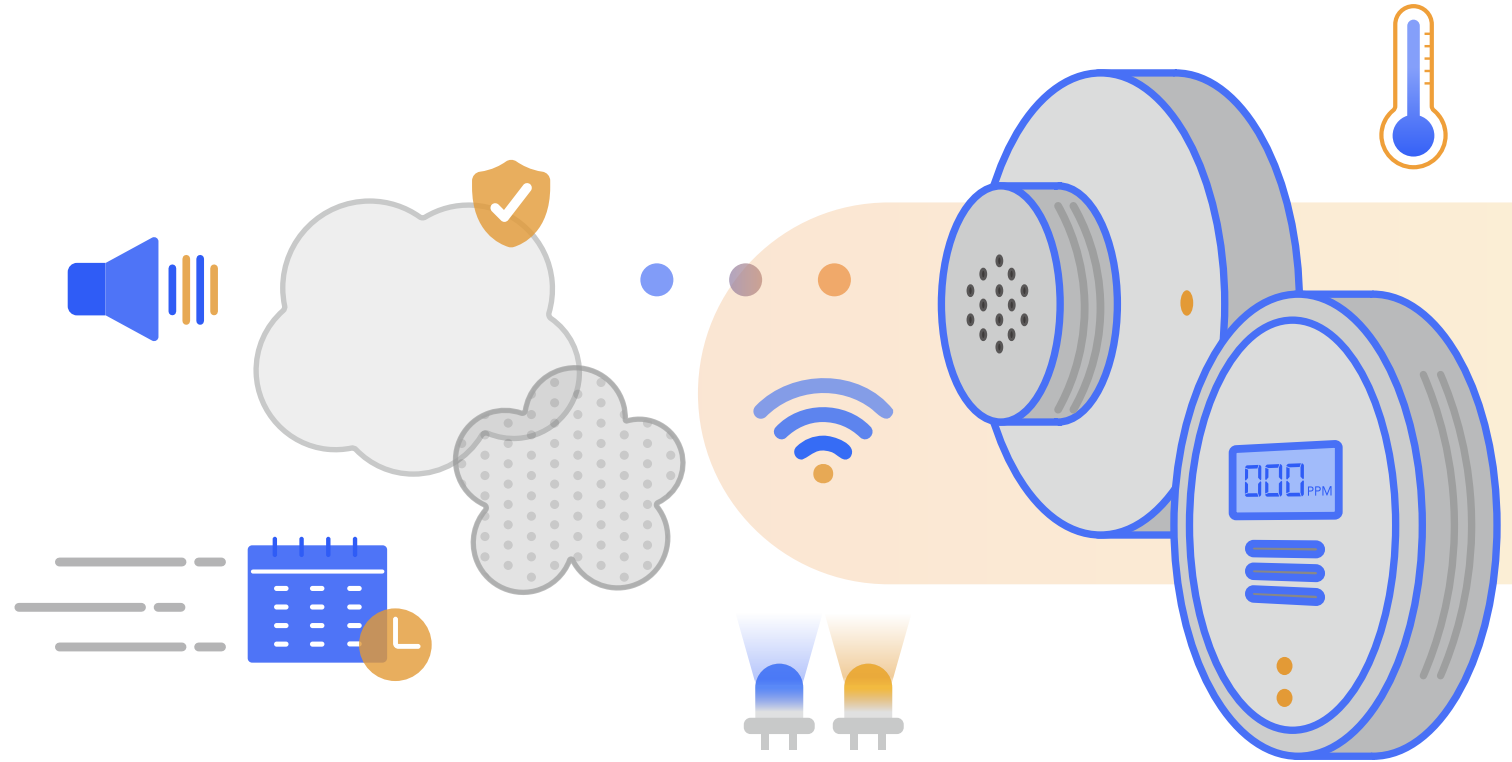

Holtek Semiconductor Inc.

**Holtek Semiconductor Inc. (Headquarters)**  
No.3, Creation Rd. II, Science park, Hsinchu 300, Taiwan  
Email: sales@holtek.com

**Holtek Semiconductor Inc. (Taipei Sales Office)**  
4F-2, No. 3-2, YuanQu St., Nankang Software Park,  
Taipei 115, Taiwan  
Email: sales@holtek.com.tw

**Holtek Semiconductor (China) Inc.**  
Room 101, Office Building 10, Xinzhu Yuan, No. 4 Xinzhu Road,  
Songshan Lake, Dongguan, China  
Email: sales@holtek.com.cn

**Holtek Semiconductor (India) Pvt.Ltd. (Delhi Branch)**  
Premises No. JA0608, 6th Floor, DLF Tower A, Jasola,  
New Delhi-110025  
Email: bharath@holtek.com.tw

**Holtek Semiconductor (India) Pvt.Ltd.**  
The Oriental Towers No. 461, 2nd Floor, 4th Sector,  
17th Cross Rd, HSR Layout, Bengaluru, Karnataka 560102  
Email: Indiasales@holtek.com.tw

Feb. 2026\_V002

*Sharing Success Through Excellence*



Holtek  
Official Website



Best Modules  
Online Shop