

Features

- Operating voltage: 3.0V~5.5V
- Built-in seven circuits
 - 2-level output:
 - 2 circuits for vertical CCD clock driver
 - Output voltage level (typ.) = -9V to 0V
 - 3-level output:
 - 4 circuits for vertical CCD clock driver
 - Output voltage level (typ.) = -9V to 15V
 - 2-level output:
 - 1 circuit for shutter driver
 - Output voltage level (typ.) = -9V to 17V
- Switchable between NTSC (EIA) and PAL (CCIR) modes
- 24-pin SSOP (150mil) package

General Description

HT82V806 is a CMOS vertical clock driver and shutter driver IC for CCD area sensors. It has the capability of

converting the voltage and impedance from the CMOS level.

Block Diagram

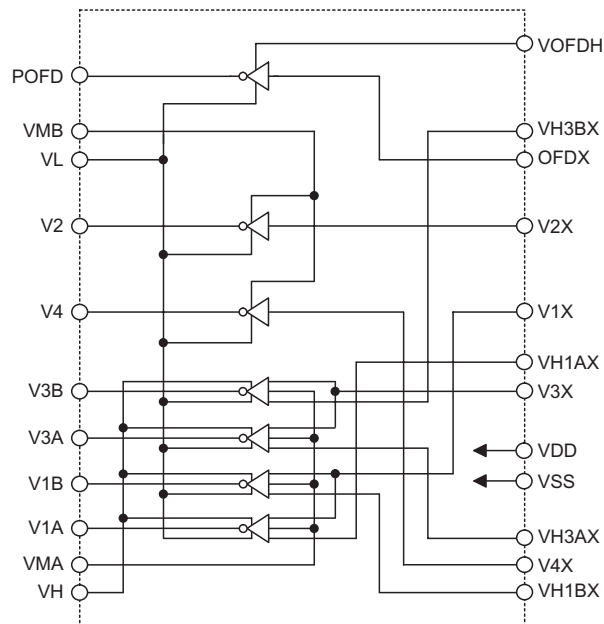

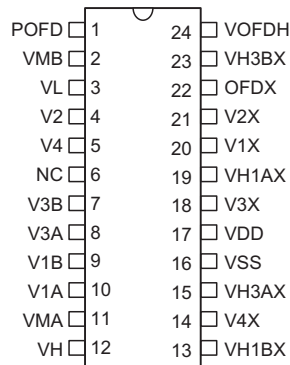
Pin Assignment

HT82V806
-24 SSOP-A
(150mil)

Pin Description

Pin No.	Pin Name	I/O	Description
1	POFD	O	Electronic shutter pulse output (High level= V_{OFDH} , low level= V_L)
2	VMB	—	Power supply for high level V2 and V4
3	VL	—	Power supply for all low level output pulses
4	V2	O	Pulse to drive vertical CCD shift register; Connect to V2
5	V4	O	Pulse to drive vertical CCD shift register; Connect to V4
6	NC	—	No connection
7	V3B	O	Pulse to drive vertical CCD shift register; Connect to V3B
8	V3A	O	Pulse to drive vertical CCD shift register; Connect to V3A
9	V1B	O	Pulse to drive vertical CCD shift register; Connect to V1B
10	V1A	O	Pulse to drive vertical CCD shift register; Connect to V1A
11	VMA	—	Power supply for intermediate level V1A, V1B, V3A and V3B
12	VH	—	Power supply for high level V1A, V1B, V3A and V3B
13	VH1BX	I	Pulse that transfers the charge of the photo-diode to the vertical shift register.
14	V4X	I	Vertical transfer pulse input
15	VH3AX	I	Pulse that transfers the charge of the photo-diode to the vertical shift register.
16	VSS	—	Negative power supply, ground
17	VDD	—	Positive power supply
18	V3X	I	Vertical transfer pulse input
19	VH1AX	I	Pulse that transfers the charge of the photo-diode to the vertical shift register.
20	V1X	I	Vertical transfer pulse input
21	V2X	I	Vertical transfer pulse input
22	OFDX	I	Electronic shutter pulse input
23	VH3BX	I	Pulse that transfers the charge of the photo-diode to the vertical shift register.
24	VOVDH	—	Power supply for high level POFD

Absolute Maximum Ratings

Supply Voltage	GND-0.3V to GND+6V	Storage Temperature	-55°C to 150°C
Input Voltage	V _{SS} -0.3V to V _{DD} +34V	Operating Temperature	-25°C to 70°C

Note: These are stress ratings only. Stresses exceeding the range specified under "Absolute Maximum Ratings" may cause substantial damage to the device. Functional operation of this device at other conditions beyond those listed in the specification is not implied and prolonged exposure to extreme conditions may affect device reliability.

Recommended Operating Conditions

Symbol	Parameter	Min.	Typ.	Max.	Unit
V _{DD}	Supply Voltage	3.0	3.3	5.5	V
V _H		—	15	—	
V _L		—	-9	—	
V _{MA} , V _{MB}		—	0	—	
V _{OFDH}		—	17	—	
V _{IN} (LOW)	Input Voltage	0	—	0.3V _{DD}	V
V _{IN} (HIGH)		0.7V _{DD}	—	V _{DD}	
NTSC	Operating Frequency	—	15.734	—	kHz
PAL		—	15.625	—	
T _{OPR}	Operating Temperature	-20	—	+70	°C

D.C. Characteristics

V_H=15V, V_L=-9V, V_{MA}=0V, V_{MB}=0V, V_{OFDH}=15V, T_a=25°C

Symbol	Parameter	Test Conditions		Min.	Typ.	Max.	Unit
		V _{DD}	Conditions				
V _{IL}	Input Low Voltage	3.3V	—	0	—	0.3V _{DD}	V
V _{IH}	Input High Voltage	3.3V	—	0.7V _{DD}	—	V _{DD}	V
V _{IL1}	Input Low Current	3.3V	V _{IL} =0V	—	—	200	μA
V _{IH1}	Input High Current	3.3V	V _{IH} =3.3V	—	—	1	μA
V _{OL}	Output Low Voltage	3.3V	I _{OL} <1μA	—	—	-8.9	V
V _{OMLa}	Output Intermediate Voltage	3.3V	I _{OMLa} <1μA	—	—	0.1	V
V _{OMHa}			I _{OMHa} <1μA	—	—	0.1	V
V _{OMLb}			I _{OMLb} <1μA	—	—	0.1	V
V _{OMHb}			I _{OMHb} <1μA	—	—	0.1	V
R _{ONH}	Output ON Resistance	3.3V	I _{OH} =20mA	—	30	—	Ω
R _{ONOFH}			I _{OFDH} =20mA	—	20	—	Ω
R _{ONM}			I _{OM} =20mA	—	25	—	Ω
R _{ONL}			I _{OL} =20mA	—	20	—	Ω
I _{DD}	Static Current	3.3V	—	—	—	2.0	μA
I _H				—	—	200	μA
I _{OFDH}				—	—	200	μA
I _M				—	—	200	μA
I _L				—	—	200	μA

Application Circuits

Equivalent Circuits

While V_{1A} and V_{3A} (or V_{1B} and V_{3B}) are measured, V_{1B} and V_{3B} (or V_{1A} and V_{3A}) are open.

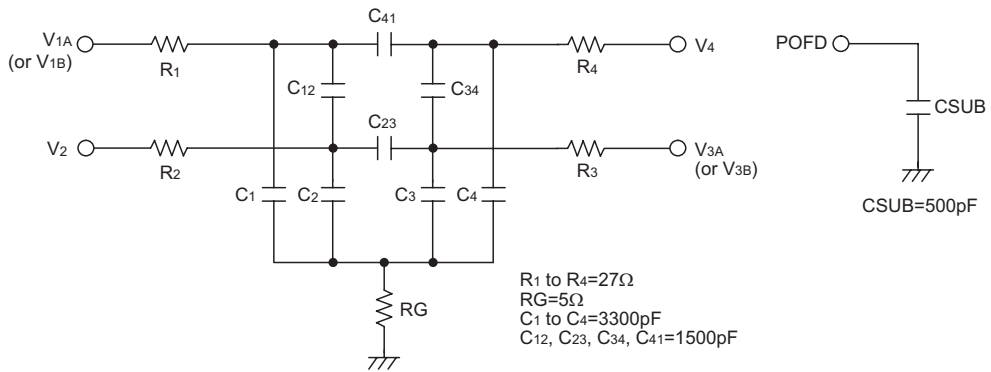

Package Information

24-pin SSOP (150mil) Outline Dimensions

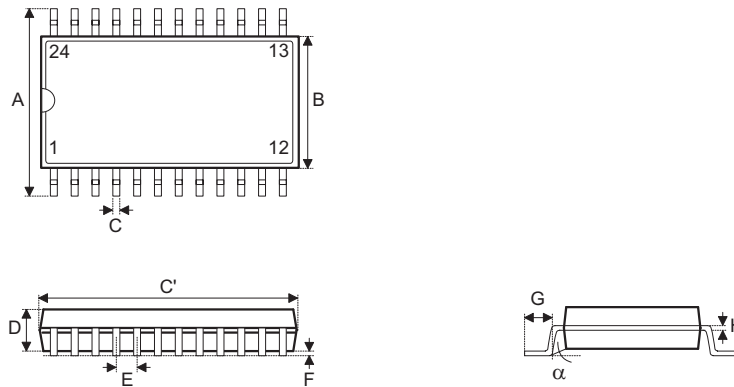

Symbol	Dimensions in mil		
	Min.	Nom.	Max.
A	228	—	244
B	150	—	157
C	8	—	12
C'	335	—	346
D	54	—	60
E	—	25	—
F	4	—	10
G	22	—	28
H	7	—	10
α	0°	—	8°

Product Tape and Reel Specifications

Reel Dimensions

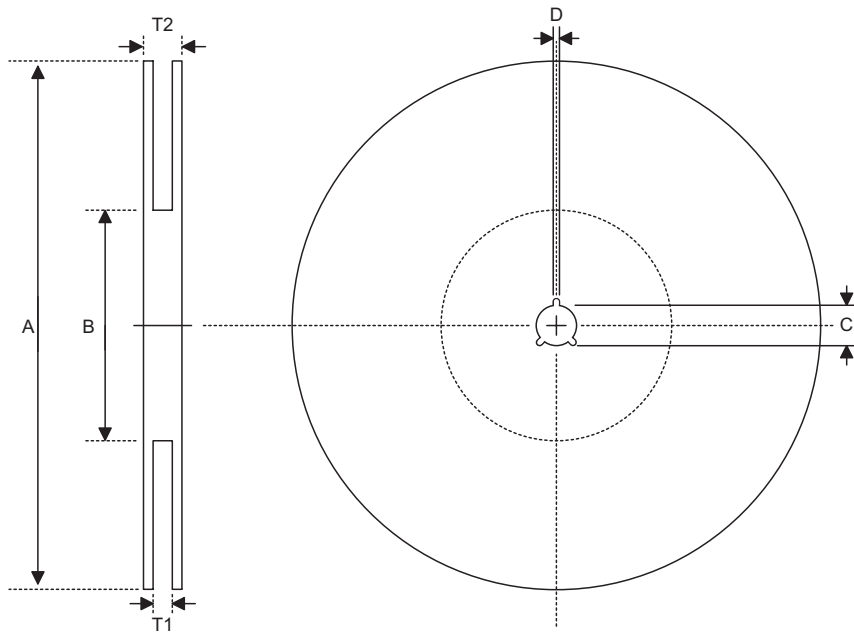

SSOP 24N (150mil)

Symbol	Description	Dimensions in mm
A	Reel Outer Diameter	330±1.0
B	Reel Inner Diameter	62±1.5
C	Spindle Hole Diameter	13.0+0.5 -0.2
D	Key Slit Width	2.0±0.5
T1	Space Between Flange	16.8+0.3 -0.2
T2	Reel Thickness	22.2±0.2

Carrier Tape Dimensions

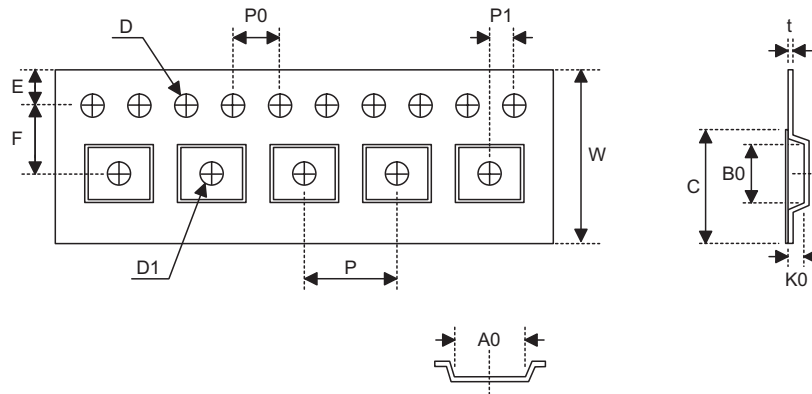

SSOP 24N (150mil)

Symbol	Description	Dimensions in mm
W	Carrier Tape Width	16.0+0.3 -0.1
P	Cavity Pitch	12.0±0.1
E	Perforation Position	1.75±0.1
F	Cavity to Perforation (Width Direction)	7.5±0.1
D	Perforation Diameter	1.5+0.1
D1	Cavity Hole Diameter	1.5+0.25
P0	Perforation Pitch	4.0±0.1
P1	Cavity to Perforation (Length Direction)	2.0±0.1
A0	Cavity Length	8.2±0.1
B0	Cavity Width	8.6±0.1
K0	Cavity Depth	3.0±0.1
t	Carrier Tape Thickness	0.35±0.05
C	Cover Tape Width	13.3

Holtek Semiconductor Inc. (Headquarters)

No.3, Creation Rd. II, Science Park, Hsinchu, Taiwan
Tel: 886-3-563-1999
Fax: 886-3-563-1189
<http://www.holtek.com.tw>

Holtek Semiconductor Inc. (Taipei Sales Office)

4F-2, No. 3-2, YuanQu St., Nankang Software Park, Taipei 115, Taiwan
Tel: 886-2-2655-7070
Fax: 886-2-2655-7373
Fax: 886-2-2655-7383 (International sales hotline)

Holtek Semiconductor Inc. (Shanghai Sales Office)

7th Floor, Building 2, No.889, Yi Shan Rd., Shanghai, China 200233
Tel: 021-6485-5560
Fax: 021-6485-0313
<http://www.holtek.com.cn>

Holtek Semiconductor Inc. (Shenzhen Sales Office)

5/F, Unit A, Productivity Building, Cross of Science M 3rd Road and Gaoxin M 2nd Road, Science Park, Nanshan District, Shenzhen, China 518057
Tel: 0755-8616-9908, 8616-9308
Fax: 0755-8616-9533

Holtek Semiconductor Inc. (Beijing Sales Office)

Suite 1721, Jinyu Tower, A129 West Xuan Wu Men Street, Xicheng District, Beijing, China 100031
Tel: 010-6641-0030, 6641-7751, 6641-7752
Fax: 010-6641-0125

Holtek Semiconductor Inc. (Chengdu Sales Office)

709, Building 3, Champagne Plaza, No.97 Dongda Street, Chengdu, Sichuan, China 610016
Tel: 028-6653-6590
Fax: 028-6653-6591

Holmate Semiconductor, Inc. (North America Sales Office)

46729 Fremont Blvd., Fremont, CA 94538
Tel: 510-252-9880
Fax: 510-252-9885
<http://www.holmate.com>

Copyright © 2006 by HOLTEK SEMICONDUCTOR INC.

The information appearing in this Data Sheet is believed to be accurate at the time of publication. However, Holtek assumes no responsibility arising from the use of the specifications described. The applications mentioned herein are used solely for the purpose of illustration and Holtek makes no warranty or representation that such applications will be suitable without further modification, nor recommends the use of its products for application that may present a risk to human life due to malfunction or otherwise. Holtek's products are not authorized for use as critical components in life support devices or systems. Holtek reserves the right to alter its products without prior notification. For the most up-to-date information, please visit our web site at <http://www.holtek.com.tw>.