

Features

- Operating voltage: 3.5V~5.5V
- Differential input
- Power down control
- Bellcore CAS detection (Type II)
- 3.58MHz clock input
- Low standby current
- High sensitivity: -33dBm
- Data valid output
- 16-pin DIP/SOP package

Applications

- Feature phone system
- Caller ID with Call Waiting
- Computer telephony interface products
- Analog Display Service Interface (ADSI)

General Description

The HT9033 is a CPE Alerting Signal (CAS) tone receiver integrated with digital filter/detector and analog front end circuit. The HT9033 using analog filter techniques to achieve very high precision detection for the present of CAS tone.

It is ideal for receiving physical layer signal like Bellcore's CPE Alerting Signal (Type II caller ID) and similar evolving services like ETS/BT.

Block Diagram

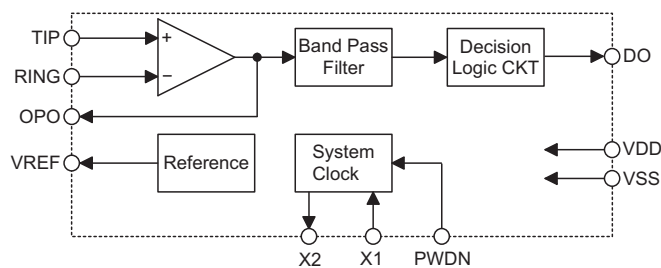

Pin Assignment

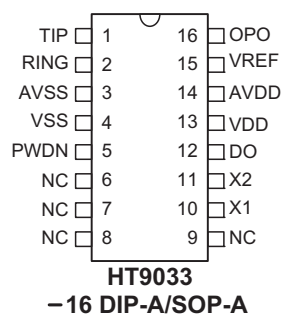

Pin Description

Pin Name	I/O	Description
TIP	I	This pin is connected to the tip side of the twisted pair wires.
RING	I	This pin is connected to the ring side of the twisted pair wires.
OPO	O	Output of OP AMP
VREF	O	Reference voltage output, normally 1/2 V _{DD} .
X1	I	A crystal or ceramic resonator should be connected to this pin and X2. This pin may be driven from an external clock source.
X2	O	A crystal or ceramic resonator should be connected to this pin and X1.
DO	O	CAS detection output. Active high.
PDWN	I	A logic "1" on this pin puts the chip in power down mode. When a logic "0" is on this pin, the chip in power up mode. This is a Schmitt trigger input.
VDD	—	Positive power
VSS	—	Negative power, ground
AVDD	—	Analog positive power
AVSS	—	Analog negative power
NC	—	No connection

Absolute Maximum Ratings

Voltages are referenced to V_{SS}, except where noted.

Supply Voltage-0.5V to 6.0V All Input Voltages.....25mW

Operating Temperature Range0°C to 70°C Storage Temperature Range-40°C to 150°C

Note: These are stress ratings only. Stresses exceeding the range specified under "Absolute Maximum Ratings" may cause substantial damage to the device. Functional operation of this device at other conditions beyond those listed in the specification is not implied and prolonged exposure to extreme conditions may affect device reliability.

D.C. Characteristics

Ta=25°C

Symbol	Parameter	Test Conditions		Min.	Typ.	Max.	Unit
		V _{DD}	Conditions				
V _{DD}	Supply Voltage	—	—	3.5	—	5.5	V
AV _{DD}	Supply Voltage	3.5V~5.5V	AV _{DD} =V _{DD}	V _{DD}	—	V _{DD}	V
I _{DD}	Operating Current	5V	PDWN=0, 3.58MHz on	—	2.5	3	mA
I _{STBY}	Standby Current	5V	PDWN=1, 3.58MHz off	—	1	2	μA
V _{IL}	"Low" Input Voltage	5V	—	—	—	0.3	V _{DD}
V _{IH}	"High" Input Voltage	5V	—	0.7	—	—	V _{DD}
I _{OL}	Output Source Current (DO)	5V	V _{OL} =0.1V _{DD}	—	0.8	—	mA
I _{OH}	Output Sink Current (DO)	5V	V _{OH} =0.9V _{DD}	—	-0.3	—	mA
f _{SYS}	System Clock	—	—	—	3.58	—	MHz

A.C. Characteristics

Ta=25°C

Symbol	Parameter	Test Conditions		Min.	Typ.	Max.	Unit
		V _{DD}	Conditions				
	Low Tone Frequency	5V	—	—	2130	—	Hz
	High Tone Frequency	5V	—	—	2750	—	Hz
	Frequency Deviation Acceptance	5V	Range within which, tones are accepted	—	—	±0.7	%
	Frequency Deviation Reject	5V	Range outside of which, tones are rejected	±2.5	—	—	%
	Acceptable Signal Level per Tone	5V	No speech	-33	—	0	dBm
	Reject Signal Level per Tone	5V	No speech	—	-36	—	dBm
	Twist Accept Limit	5V	—	—	±7	—	dB
	Signal to Noise Ratio	5V	—	—	-19	—	dB
t _{DET}	Present Detect Time	5V	—	—	55	—	ms

Clock (System Frequency)

Ta=25°C

Symbol	Parameter	Test Conditions		Min.	Typ.	Max.	Unit
		V _{DD}	Conditions				
f _C	Clock Input Frequency	5V	—	3.5759	3.5795	3.5831	MHz
t _{LHCL}	Clock Input Rising Time	5V	—	—	—	110	ns
t _{HLCL}	Clock Input Falling Time	5V	—	—	—	110	ns
DC _{CL}	Clock Input Duty Cycle	5V	—	40	50	60	%

Functional Description
Power Down Mode

If PDWN pin= 1, the HT9033 is in reset status and the CAS detector is at power down mode, all function is disable. The oscillator circuit will be stop.

If PDWN pin= 0, CAS detector is activated.

CAS Detector Output Signal

The output pin DO is CMOS structure. At the normal status (CAS tone is not presence), the DO pin output low. When the CAS tone is detected, the DO pin will output high level.

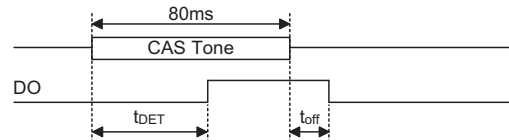
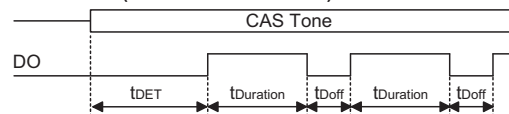
CAS Detector Timing
Condition 1 (Standard CAS Tone):

Condition 2 (Continuous CAS Tone):

Parameter	Note	Min.	Typ.	Max.	Unit
t _{DET}	CAS Detecting Time	—	55	—	ms
t _{off}	DO Off Time	—	8	—	ms
t _{Duration}	DO Duration Time	—	145	—	ms
t _{DOff}	DO Duration Off Time	—	48	—	ms

If the CAS tone is presence more than t_{DET} time, the CAS tone will be detected, then the DO will output high.

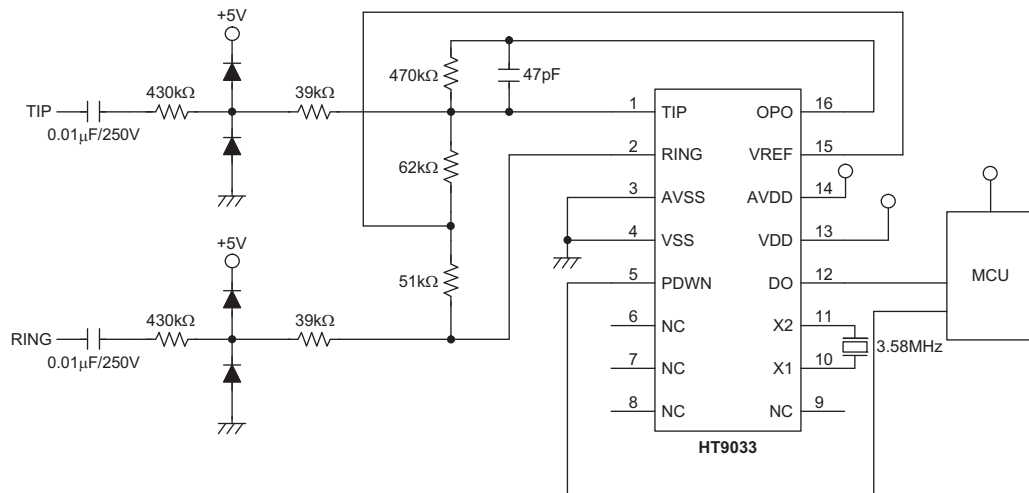
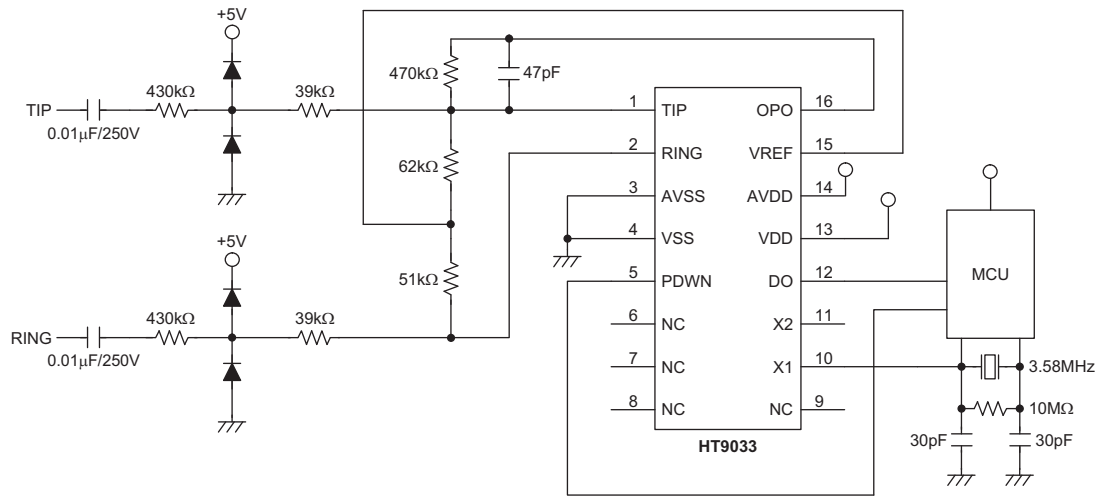
Application Circuits



Package Information

16-pin DIP (300mil) Outline Dimensions

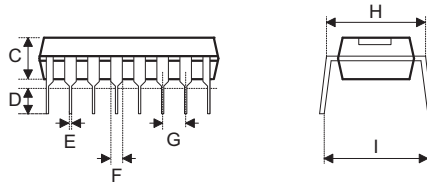
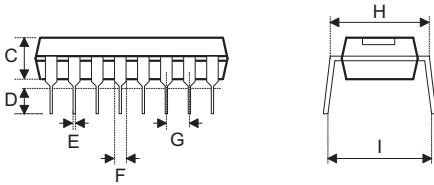
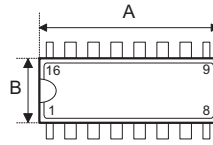
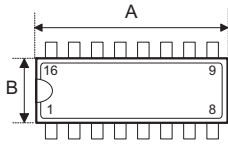

Fig1. Full Lead Packages

Fig2. 1/2 Lead Packages

- MS-001d (see fig1)

Symbol	Dimensions in mil		
	Min.	Nom.	Max.
A	780	—	880
B	240	—	280
C	115	—	195
D	115	—	150
E	14	—	22
F	45	—	70
G	—	100	—
H	300	—	325
I	—	—	430

- MS-001d (see fig2)

Symbol	Dimensions in mil		
	Min.	Nom.	Max.
A	735	—	775
B	240	—	280
C	115	—	195
D	115	—	150
E	14	—	22
F	45	—	70
G	—	100	—
H	300	—	325
I	—	—	430

- MO-095a (see fig2)

Symbol	Dimensions in mil		
	Min.	Nom.	Max.
A	745	—	785
B	275	—	295
C	120	—	150
D	110	—	150
E	14	—	22
F	45	—	60
G	—	100	—
H	300	—	325
I	—	—	430

16-pin SOP (300mil) Outline Dimensions

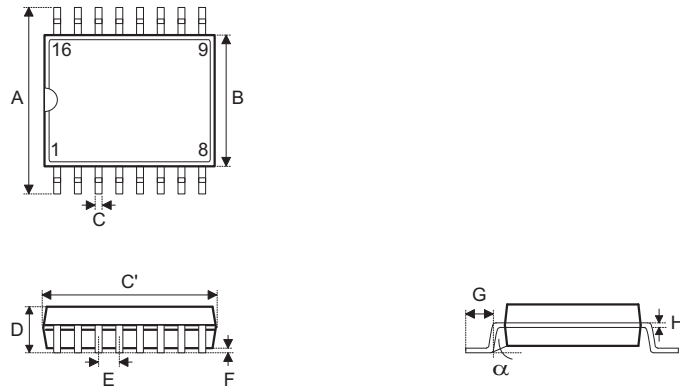

• MS-013

Symbol	Dimensions in mil		
	Min.	Nom.	Max.
A	393	—	419
B	256	—	300
C	12	—	20
C'	398	—	413
D	—	—	104
E	—	50	—
F	4	—	12
G	16	—	50
H	8	—	13
α	0°	—	8°

Product Tape and Reel Specifications

Reel Dimensions

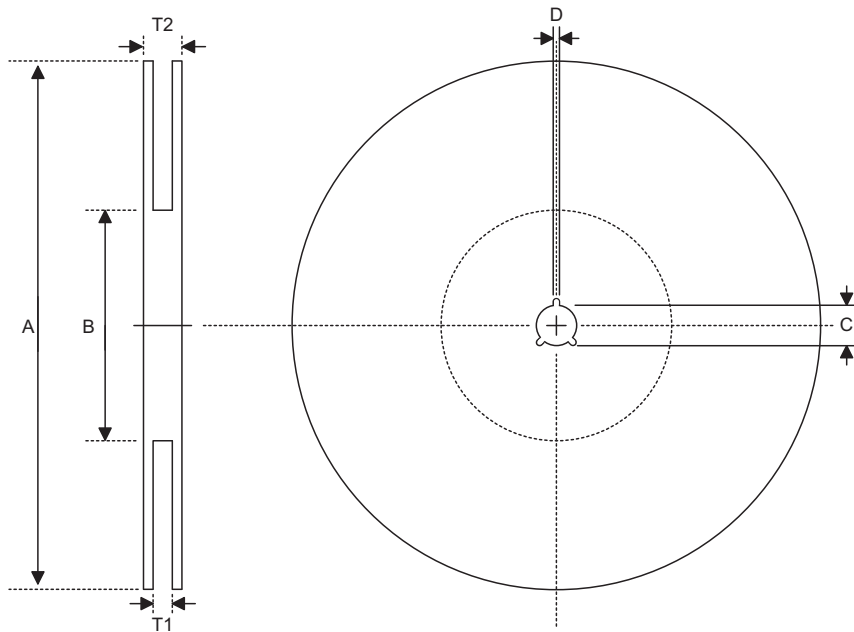

SOP 16W (300mil)

Symbol	Description	Dimensions in mm
A	Reel Outer Diameter	330.0±1.0
B	Reel Inner Diameter	100.0±1.5
C	Spindle Hole Diameter	13.0 ^{+0.5/-0.2}
D	Key Slit Width	2.0±0.5
T1	Space Between Flange	16.8 ^{+0.3/-0.2}
T2	Reel Thickness	22.2±0.2

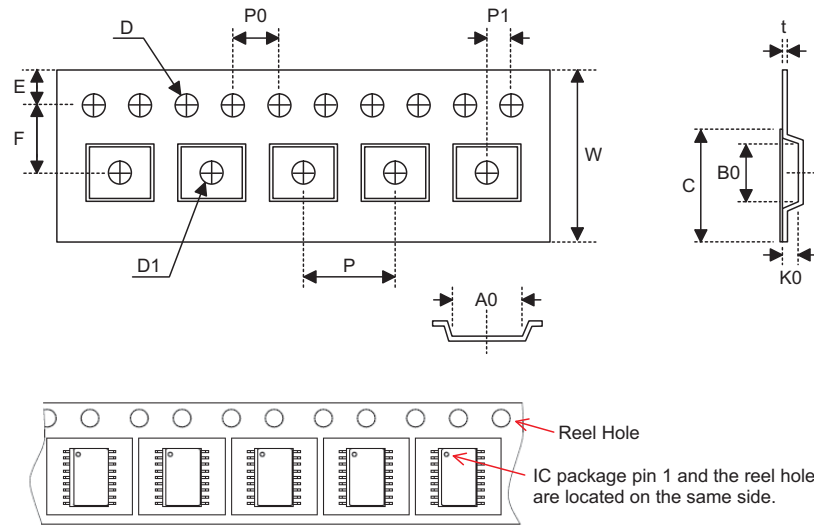
Carrier Tape Dimensions

SOP 16W (300mil)

Symbol	Description	Dimensions in mm
W	Carrier Tape Width	16.0±0.2
P	Cavity Pitch	12.0±0.1
E	Perforation Position	1.75±0.10
F	Cavity to Perforation (Width Direction)	7.5±0.1
D	Perforation Diameter	1.50 ^{+0.10/-0.00}
D1	Cavity Hole Diameter	1.50 ^{+0.25/-0.00}
P0	Perforation Pitch	4.0±0.1
P1	Cavity to Perforation (Length Direction)	2.0±0.1
A0	Cavity Length	10.9±0.1
B0	Cavity Width	10.8±0.1
K0	Cavity Depth	3.0±0.1
t	Carrier Tape Thickness	0.30±0.05
C	Cover Tape Width	13.3±0.1

Holtek Semiconductor Inc. (Headquarters)

No.3, Creation Rd. II, Science Park, Hsinchu, Taiwan
Tel: 886-3-563-1999
Fax: 886-3-563-1189
<http://www.holtek.com.tw>

Holtek Semiconductor Inc. (Taipei Sales Office)

4F-2, No. 3-2, YuanQu St., Nankang Software Park, Taipei 115, Taiwan
Tel: 886-2-2655-7070
Fax: 886-2-2655-7373
Fax: 886-2-2655-7383 (International sales hotline)

Holtek Semiconductor Inc. (Shanghai Sales Office)

G Room, 3 Floor, No.1 Building, No.2016 Yi-Shan Road, Minhang District, Shanghai, China 201103
Tel: 86-21-5422-4590
Fax: 86-21-5422-4705
<http://www.holtek.com.cn>

Holtek Semiconductor Inc. (Shenzhen Sales Office)

5F, Unit A, Productivity Building, Gaoxin M 2nd, Middle Zone Of High-Tech Industrial Park, ShenZhen, China 518057
Tel: 86-755-8616-9908, 86-755-8616-9308
Fax: 86-755-8616-9722

Holtek Semiconductor Inc. (Beijing Sales Office)

Suite 1721, Jinyu Tower, A129 West Xuan Wu Men Street, Xicheng District, Beijing, China 100031
Tel: 86-10-6641-0030, 86-10-6641-7751, 86-10-6641-7752
Fax: 86-10-6641-0125

Holtek Semiconductor Inc. (Chengdu Sales Office)

709, Building 3, Champagne Plaza, No.97 Dongda Street, Chengdu, Sichuan, China 610016
Tel: 86-28-6653-6590
Fax: 86-28-6653-6591

Holtek Semiconductor (USA), Inc. (North America Sales Office)

46729 Fremont Blvd., Fremont, CA 94538, USA
Tel: 1-510-252-9880
Fax: 1-510-252-9885
<http://www.holtek.com>

Copyright © 2009 by HOLTEK SEMICONDUCTOR INC.

The information appearing in this Data Sheet is believed to be accurate at the time of publication. However, Holtek assumes no responsibility arising from the use of the specifications described. The applications mentioned herein are used solely for the purpose of illustration and Holtek makes no warranty or representation that such applications will be suitable without further modification, nor recommends the use of its products for application that may present a risk to human life due to malfunction or otherwise. Holtek's products are not authorized for use as critical components in life support devices or systems. Holtek reserves the right to alter its products without prior notification. For the most up-to-date information, please visit our web site at <http://www.holtek.com.tw>.